

**HIGH PRECISION X AXIS POSITIONING TABLE- LINEAR LEAD SCREW SLIDE**

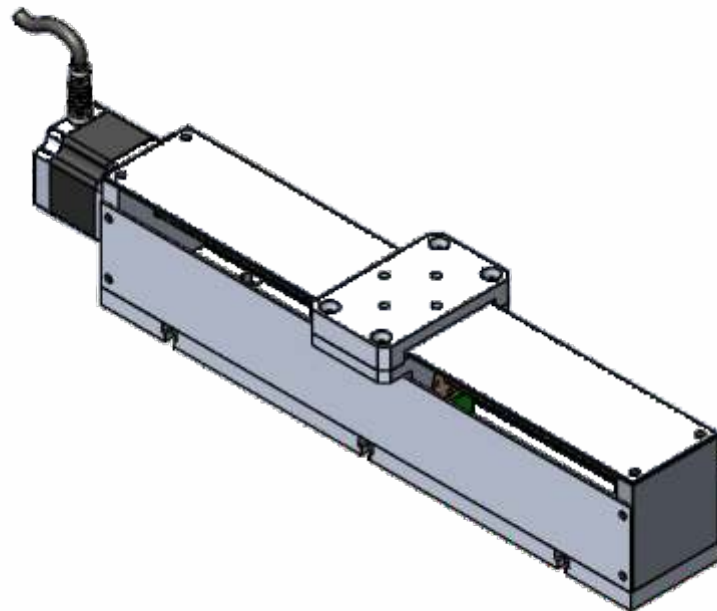

**X SLIDE WITH SHEET METAL COVER**

# HIGH PRECISION X AXIS POSITIONING TABLE- LINEAR LEAD SCREW SLIDE

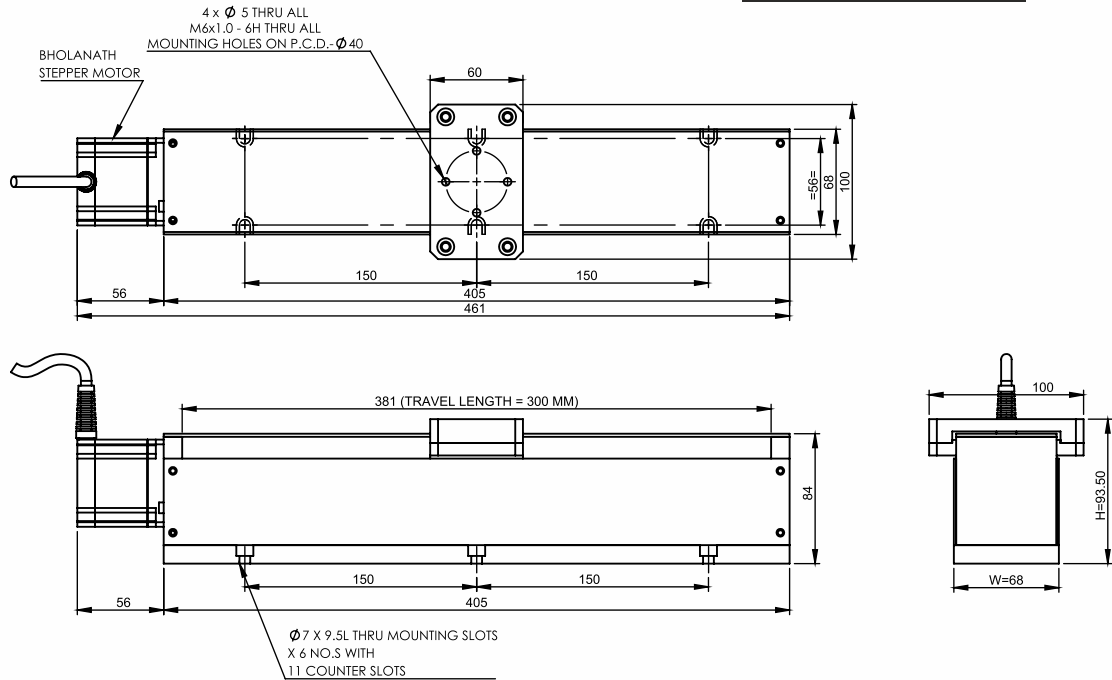
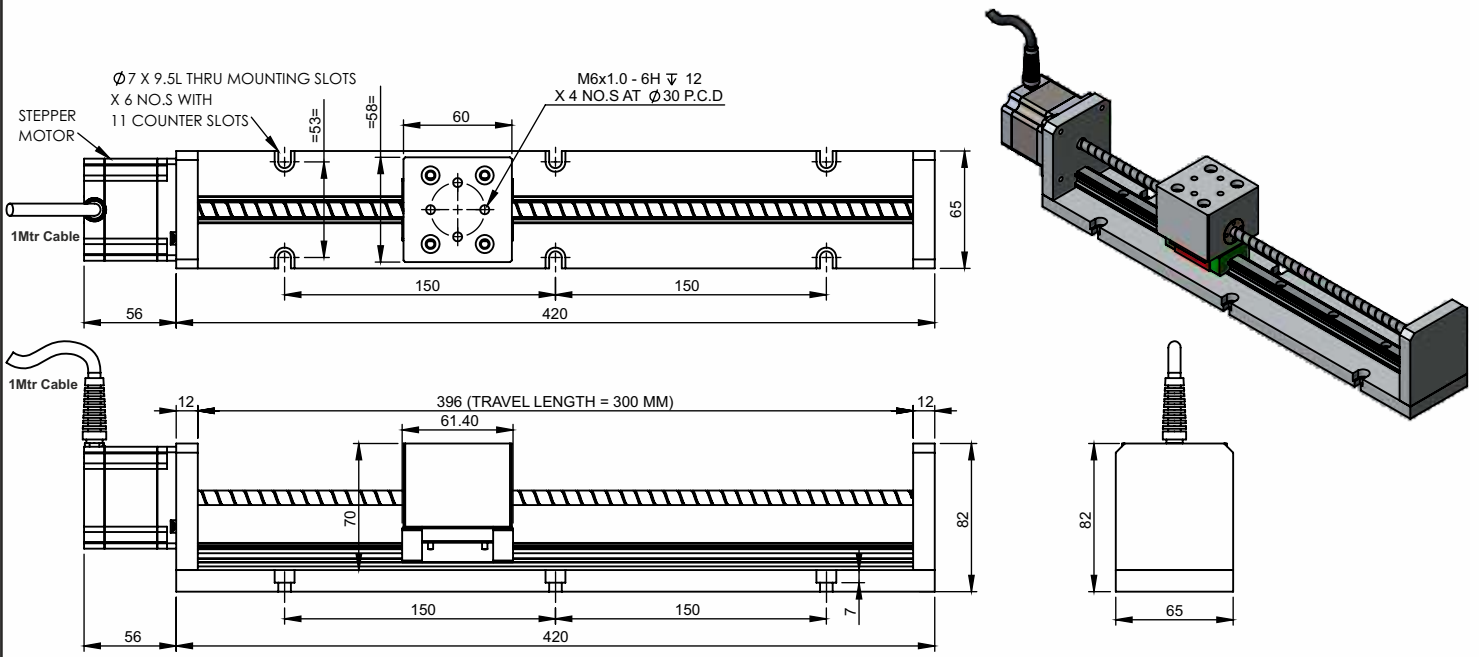

**Stepper Drive**  
**BH-SMART-4.5A**  
 Weight :- 350 gm  
 Qty 01 Nos



**Power Supply**  
**BH-48VDC**  
 Weight :- 3KG  
 Qty 01 Nos



**Stepper Drive Controller**  
**BH-SDC-01-N**  
 Weight :- 0.3 KG  
 Qty 01 Nos



## TECHNICAL DATA

| SPECIFICATION Model no BHLS-XSLIDE-300(M+E) |                                    |                 |
|---|------------------------------------|-----------------|
| 1   | Maximum load carrying capacity(kg) | 4.5             |
| 2   | Permissible Feed Speed             | 0 to 120 mm/sec |
| 3   | Positioning Accuracy (mm)          | ≤ 0.05          |
| 4   | Degree Of protection               | IP 40           |
| 5   | Total Weight of slide (KG)         | 3.5             |
| 6   | Total Weight of Systems (KG)       | 10.5            |

**Note:-** The Load Calculation is Based On Horizontal Movement. For Vertical Movement Kindly Consider Safety Factor Of 0.6 And Motor With Brake.

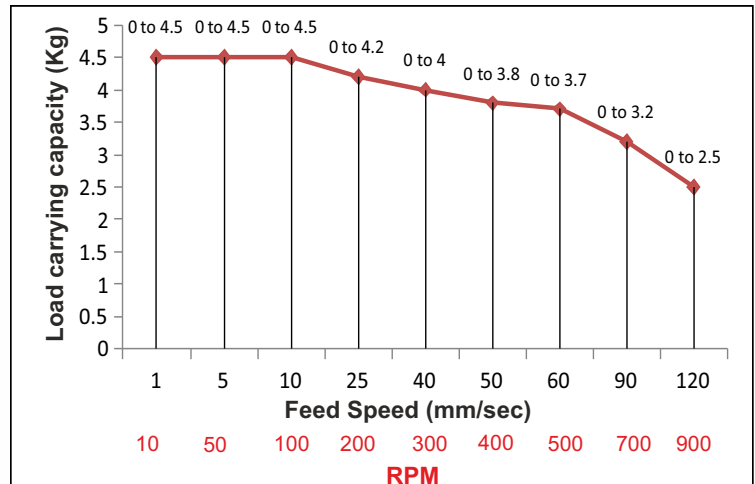

## Bholanath Precision Engineering Pvt.Ltd.

11,Kembros Ind.Estate , Sonapur Lane , Bhandup (W),Mumbai - 400078.  
 Telefax/Phone : 25662856/25664338/67993260 Email : support@bholanath.in  
 Mobile No : 9920903825/9821671733/9930514603/9819515543/9323166582.