

**HIGH PRECISION X AXIS POSITIONING TABLE - LINEAR BALL SCREW SLIDES**

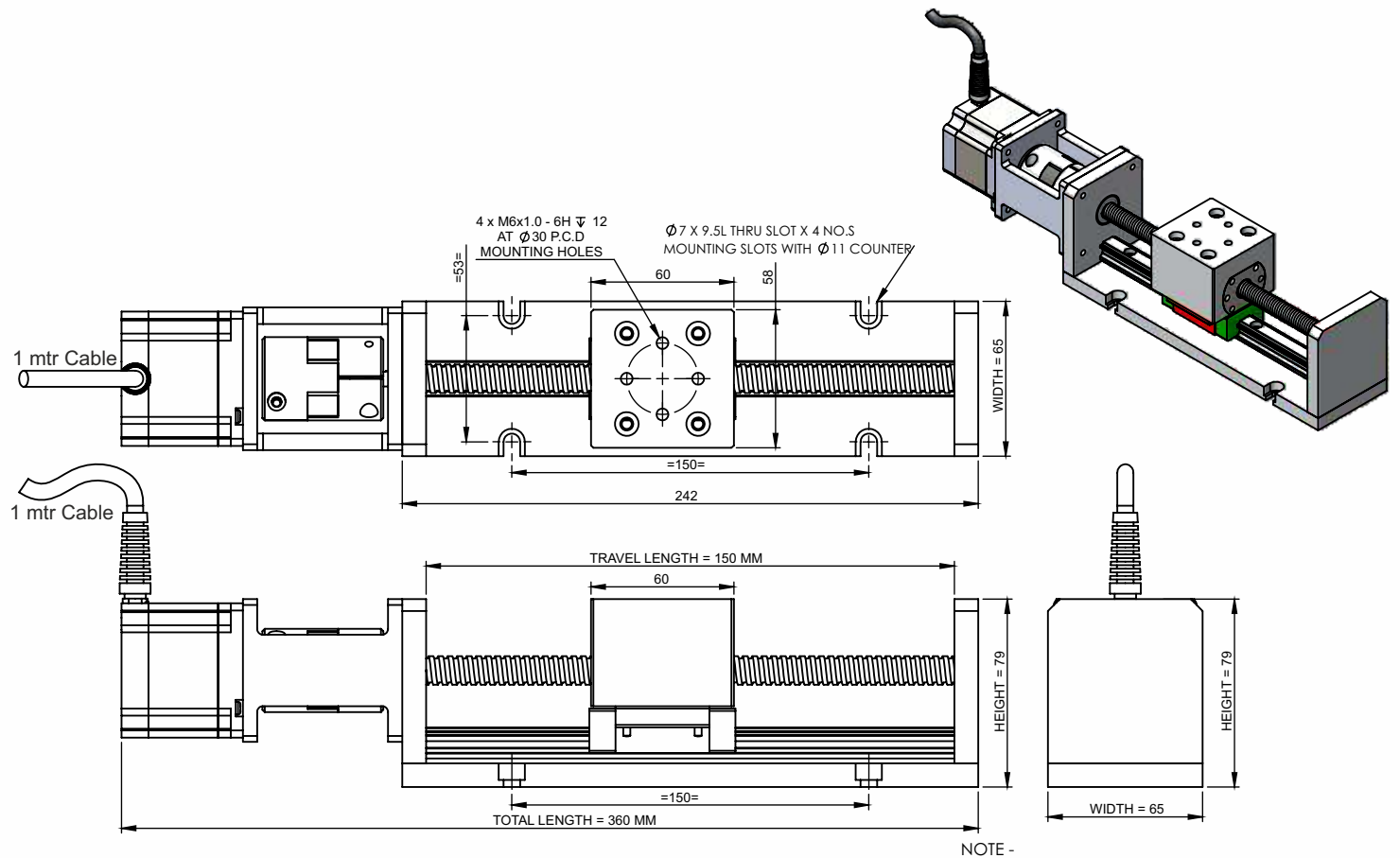

**Stepper Drive**  
**BH-SMART-2A**  
**Weight :- 250 gm**  
**Qty 01 Nos**

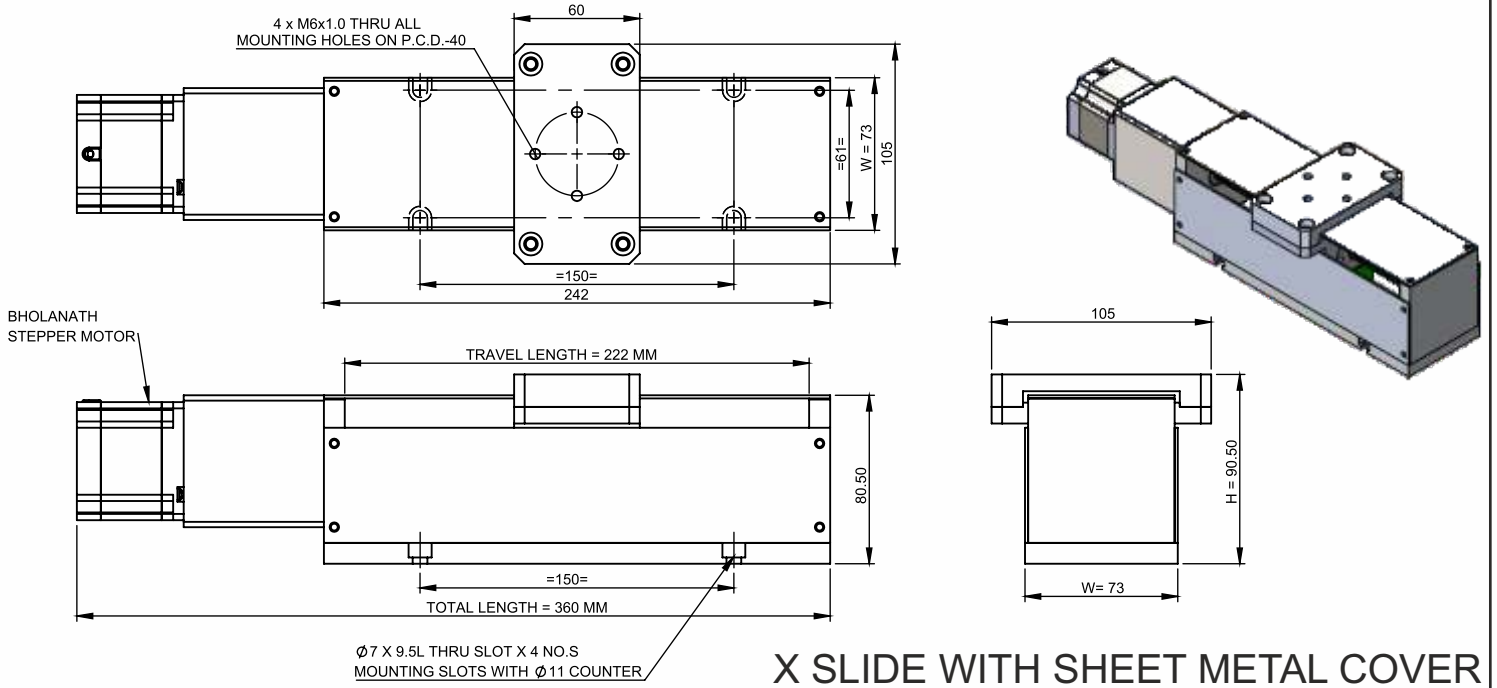

**Power Supply**  
**BH-24VDC**  
**Weight :- 2.1KG**  
**Qty 01 Nos**



**Stepper Drive Controller**  
**BH-SDC-01-N**  
**Weight :- 0.3 KG**  
**Qty 01 Nos**



**Note:-** The Load Calculation is Based On Horizontal Movement. For Vertical Movement Kindly Consider Safety Factor Of 0.6 And Motor With Brake.

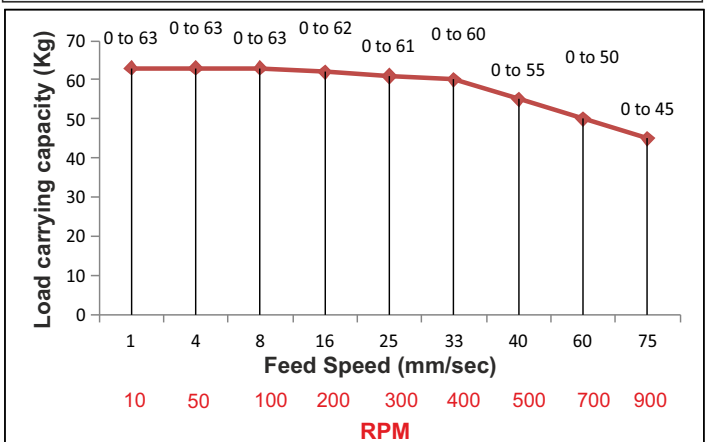

## TECHNICAL DATA

SPECIFICATION		Model no	BHBS-XSLIDE-150(M+E)
1	Maximum load carrying capacity(kg)		63
2	Permissible Feed Speed		0 to 75 mm/sec
3	Positioning Accuracy (mm)		≤ 0.02
4	Degree Of protection		IP 40
5	Total Weight of slide (KG)		3.5
6	Total Weight of systems (KG)		6.5



## Bholanath Precision Engineering Pvt.Ltd.

1002 Opposite Old Passport Office, Wagle Estate, MIDC, Thane West - 400604. India.  
**Tel Nos** - 91 - 22 - 69181700 (100 Lines) / 9821671733  
**Mobile No** : 9920903825/9821671733/9930514603/9819515543/9323166582.  
**Email Id** - support@bholanath.in/ nisha.k@bholanath.in  
**Website** - www.bholanath.in