

SPECIFICATION SHEET
Bholanath

Rotary Table
BH-RT-04 (M+E+P)

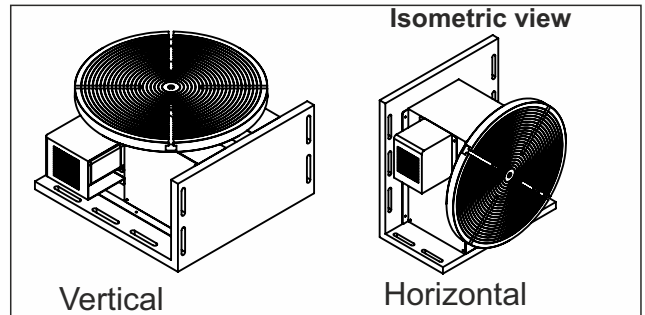

Heavy duty stepper motor Technology with accurate indexing and accurate rotation. Rotary tables used for applications in machine tool industry.

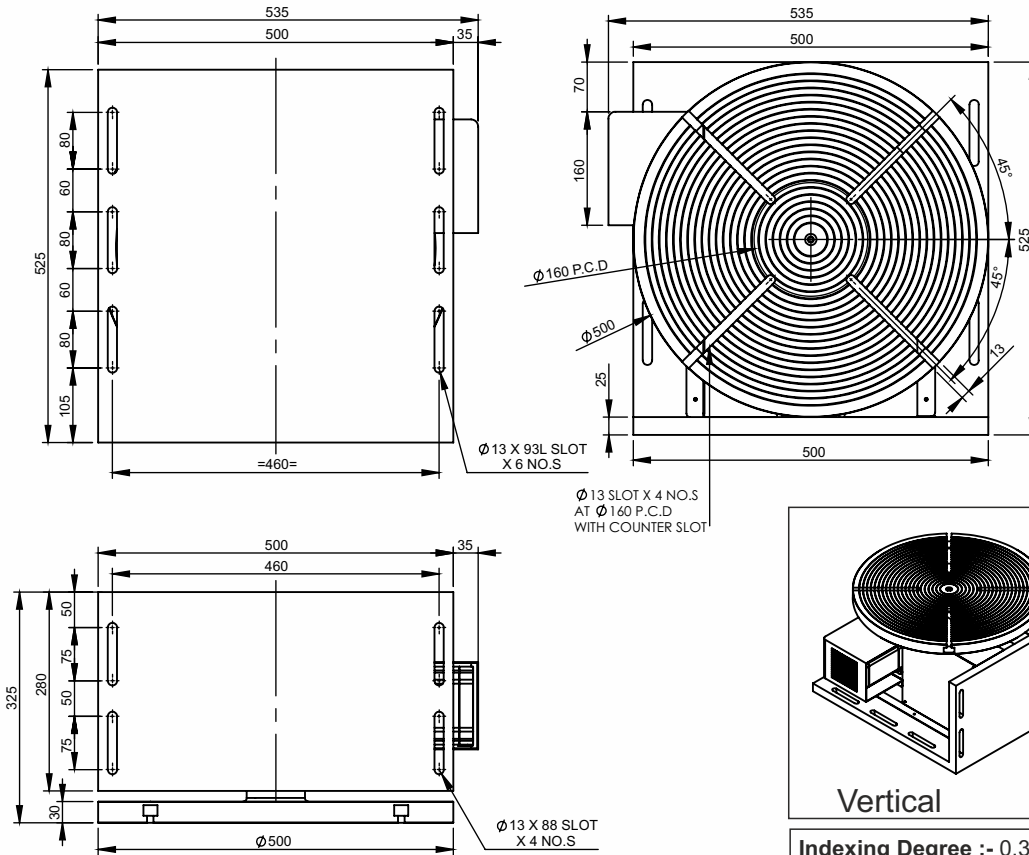

Indexing Degree :- 0.36°.3°.30°.45°.60°.90°...180°...360°...
{n(15)/1.8} where n is Indexing degree.
Example:- n=270°
=(270X15)/1.8
=2250
Result has to be whole number
(So 270° indexing is possible)
Note:- Continuous Movement up to 15RPM for 350Kg load.

BRAKE DETAILS :
Torque : 10 Nm
Voltage : 24 V
Current at 20°C - 0.85 Amps
Power Consumption at 20°C : 21.1 Watts

White ○ +
Black ○ -
24VDC

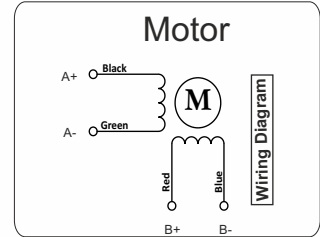

Stepper Drive
Weight:- 1.5 Kg



Control Panel

Weight:- 8Kg



Stepper Drive Controller
Weight:- 300 gm



Power Supply
Weight:- 13 kg

TECHNICAL DATA

SPECIFICATION	Model No	BH-RT-04-(M+E+P)
1	Maximum load carrying capacity(kg)	350
2	Permissible Feed Speed (RPM)	0 to 15
3	Maximum Plate Diameter (mm)	500
4	Gear Ratio of Indexing Table	15:1
5	Positioning Accuracy (Degree)	0.5
6	Degree Of protection	IP 40
7	Total Weight Of Rotary Indexing (KG)	166
8	Total Weight Of Systems (KG)	191



Bholanath Precision Engineering Pvt.Ltd.

11,Kembros Ind.Estate , Sonapur Lane , Bhandup (W),Mumbai - 400078.
Telefax/Phone : 25662856/25664338/67993260 Email : support@bholanath.in
Mobile No : 9920903825/9821671733/9930514603/9819515543/9323166582.