

SPECIFICATION SHEET
Bholanath

Rotary Table
BH-RT-03 (M+E+P)

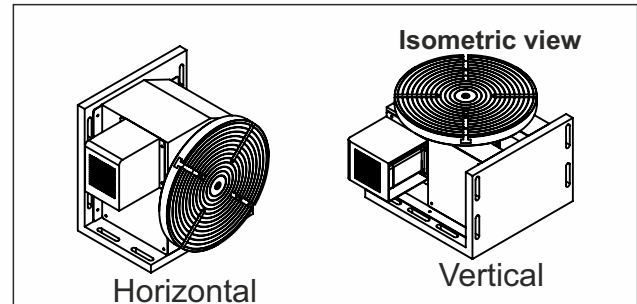

Heavy duty stepper motor Technology with accurate indexing and accurate rotation. Rotary tables used for applications in machine tool industry.

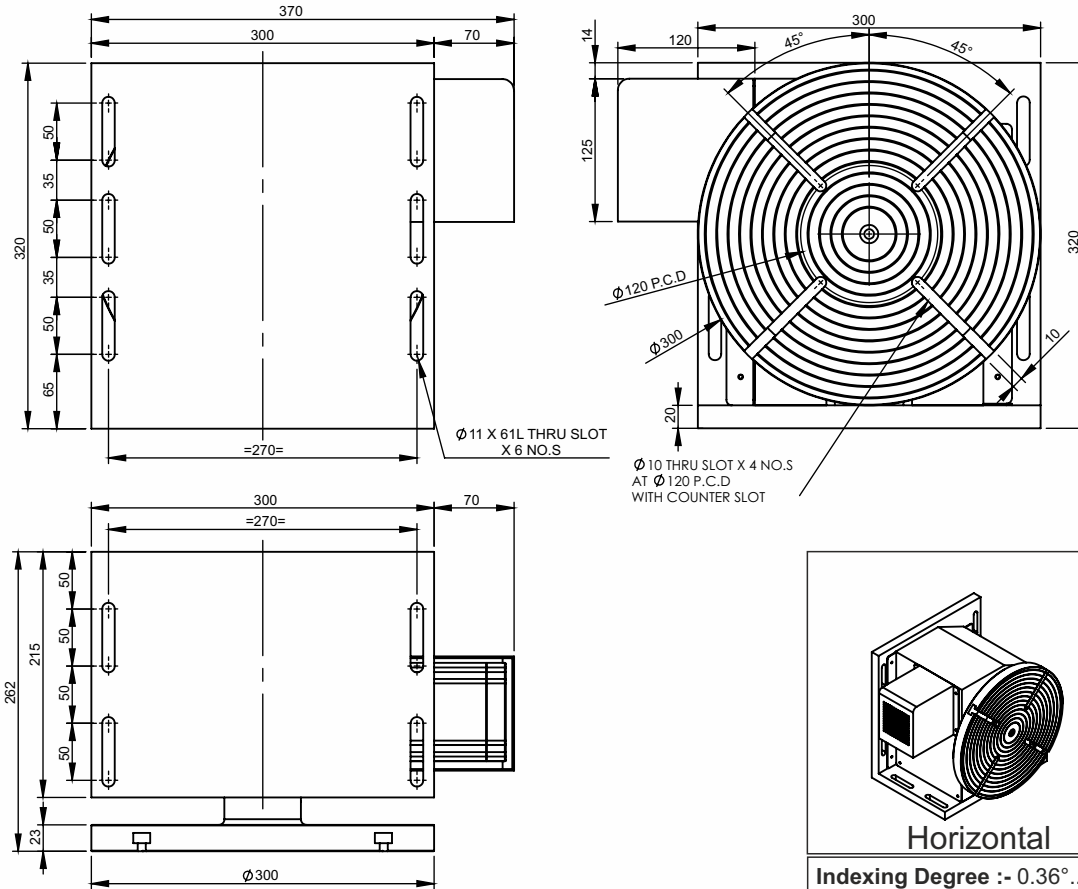

Indexing Degree :- 0.36°, 3°, 30°, 45°, 60°, 90°...180°...360°...
{n(15)/1.8} where n is Indexing degree.

Example:- $n=270^\circ$
 $= (270 \times 15) / 1.8$
 $= 2250$

Result has to be whole number
(So 270° indexing is possible)

Note:- Continuous Movement up to 15RPM for 170Kg load.

BRAKE DETAILS :
 Torque : 10 Nm
 Voltage : 24 V
 Current at 20°C - 0.85 Amps
 Power Consumption at 20°C : 21.1 Watts

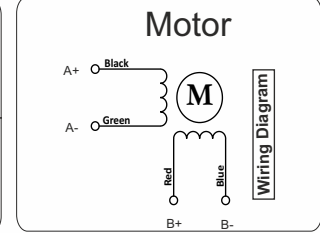
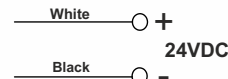

TECHNICAL DATA

SPECIFICATION Model No		BH-RT-03-(M+E+P)
1	Maximum load carrying capacity(kg)	170
2	Permissible Feed Speed (RPM)	0 to 15
3	Maximum Plate Diameter (mm)	300
4	Gear Ratio of Indexing Table	15:1
5	Positioning Accuracy (Degree)	0.5
6	Degree Of protection	IP 40
7	Total Weight Of Rotary Indexing (KG)	61
8	Total Weight Of Systems (KG)	74

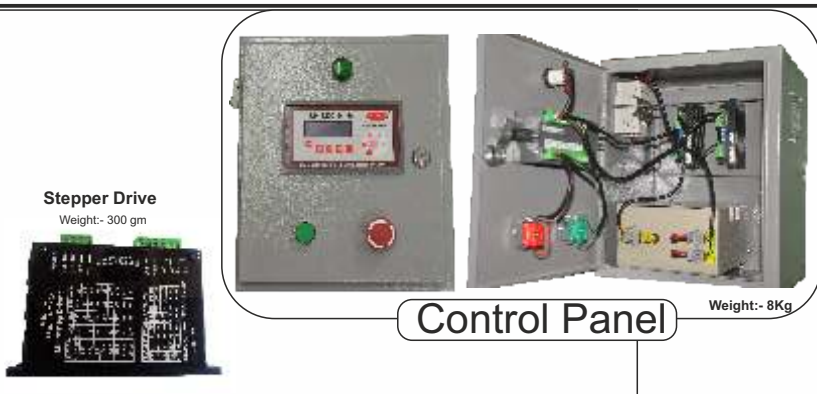

Bholanath Precision Engineering Pvt.Ltd.
 11,Kembros Ind.Estate , Sonapur Lane , Bhandup (W),Mumbai - 400078.
 Telefax/Phone : 25662856/25664338/67993260 Email : support@bholanath.in
 Mobile No : 9920903825/9821671733/9930514603/9819515543/9323166582.