

SPECIFICATION SHEET
Bholanath

Rotary Table
BH-RT-02 (M+E)

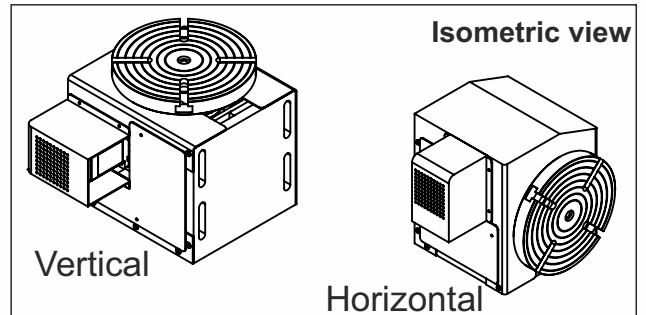

Heavy duty stepper motor Technology with accurate indexing and accurate rotation. Rotary tables used for applications in machine tool industry.

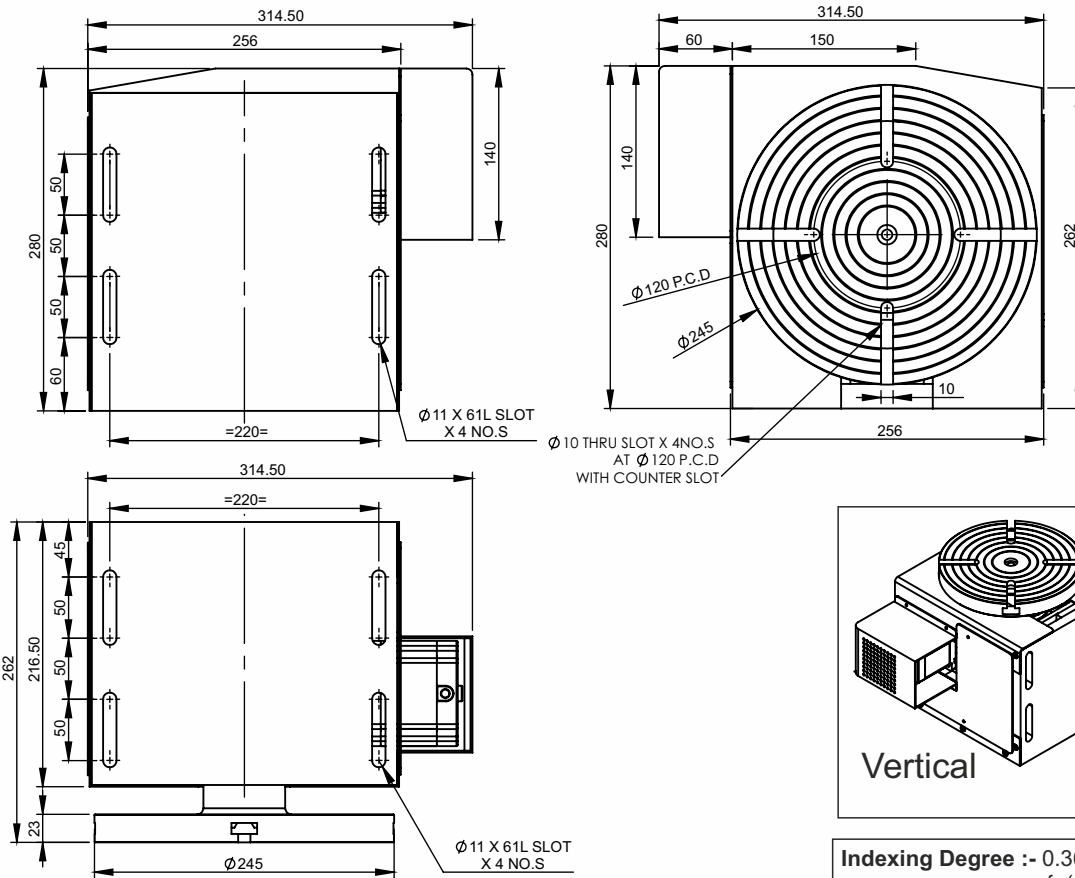

Indexing Degree :- $0.36^\circ \dots 3^\circ \dots 30^\circ, 45^\circ, 60^\circ, 90^\circ \dots 180^\circ \dots 360^\circ \dots \{n(15)/1.8\}$ where n is Indexing degree.
 Example:- $n=270^\circ$
 $= (270 \times 15) / 1.8$
 $= 2250$
 Result has to be whole number
 (So 270° indexing is possible)
Note:- Continuous Movement up to 15RPM for 100Kg load.

BRAKE DETAILS :
 Torque : 5 Nm
 Voltage : 24 V
 Current at 20°C - 0.88 Amps
 Power Consumption at 20°C : 21.1 Watts

White \ominus +
 Black \ominus -
24VDC

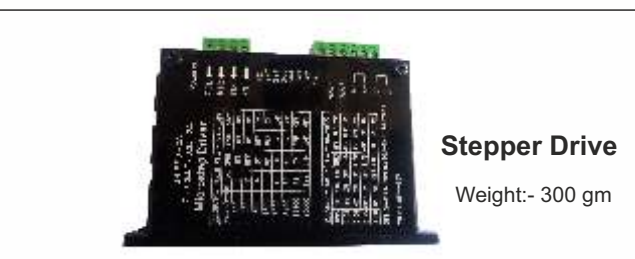
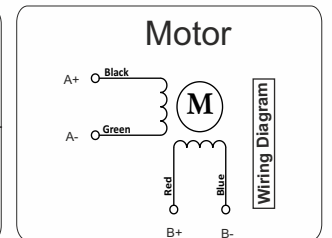

TECHNICAL DATA

SPECIFICATION	Model No	BH-RT-02-(M+E)
1	Maximum load carrying capacity(kg)	100
2	Permissible Feed Speed (RPM)	0 to 15
3	Maximum Plate Diameter (mm)	245
4	Gear Ratio of Indexing Table	15:1
5	Positioning Accuracy (Degree)	0.5
6	Degree Of protection	IP 40
7	Total Weight Of Rotary Indexing (KG)	44
8	Total Weight Of Systems (KG)	50



Bholanath Precision Engineering Pvt.Ltd.
 11,Kembros Ind.Estate , Sonapur Lane , Bhandup (W),Mumbai - 400078.
 Telefax/Phone : 25662856/25664338/67993260 Email : support@bholanath.in
 Mobile No : 9920903825/9821671733/9930514603/9819515543/9323166582.