

SPECIFICATION SHEET
Bholanath

Rotary Table
BH-RT-02 (M)

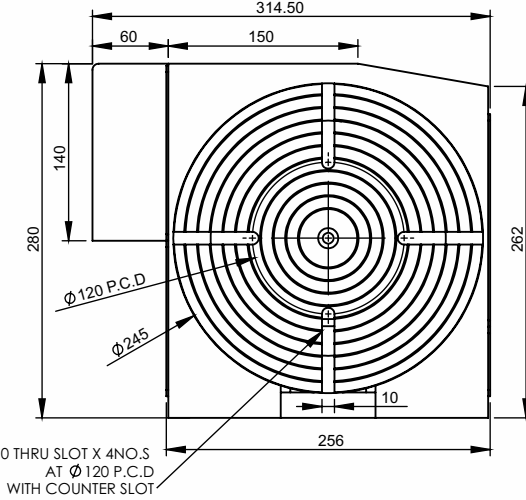

Heavy duty stepper motor Technology with accurate indexing and accurate rotation. Rotary tables used for applications in machine tool industry.

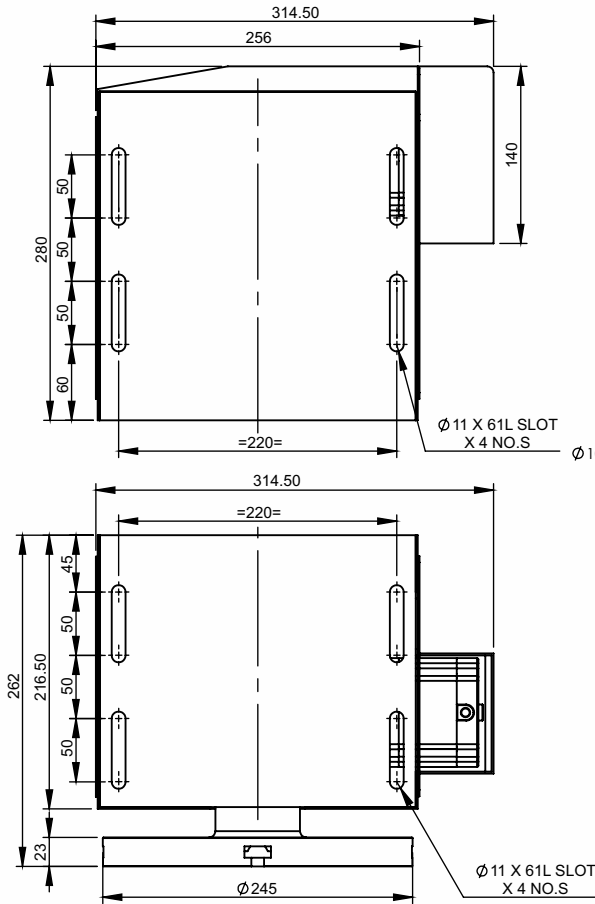

Indexing Degree :- 0.36° ..3° ..30°, 45°, 60°, 90° ... 180° ... 360° ...
{n(15)/1.8} where n is Indexing degree.

Example:- n=270°
=(270X15)/1.8
=2250
Result has to be whole number
(So 270° indexing is possible)

Note:- Continuous Movement up to 15RPM for 100Kg load.



BRAKE DETAILS :
Torque : 5 Nm
Voltage : 24 V
Current at 20°C : 0.88 Amps
Power Consumption at 20°C : 21.1 Watts

White — +
Black — -
24VDC

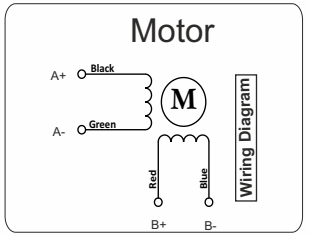

TECHNICAL DATA

SPECIFICATION Model No		BH-RT-02-(M)
1	Maximum load carrying capacity(kg)	100
2	Permissible Feed Speed (RPM)	0 to 15
3	Maximum Plate Diameter (mm)	245
4	Gear Ratio of Indexing Table	15:1
5	Positioning Accuracy (Degree)	0.5
6	Degree Of protection	IP 40
7	Total Weight Of Rotary table (KG)	44

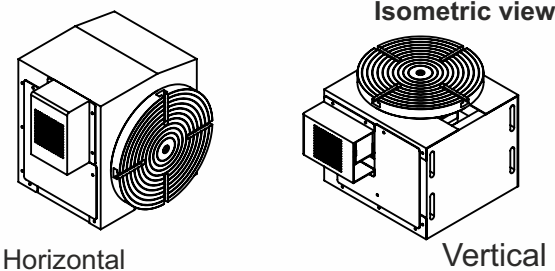

Bholanath Precision Engineering Pvt.Ltd.

11,Kembros Ind.Estate , Sonapur Lane , Bhandup (W),Mumbai - 400078.
Telefax/Phone : 25662856/25664338/67993260 Email : support@bholanath.in
Mobile No : 9920903825/9821671733/9930514603/9819515543/9323166582.