

SPECIFICATION SHEET
Bholanath

STEPPER MOTOR
BH57 SH 41 - 2804 PL-22.7
HIGH TORQUE HYBRID

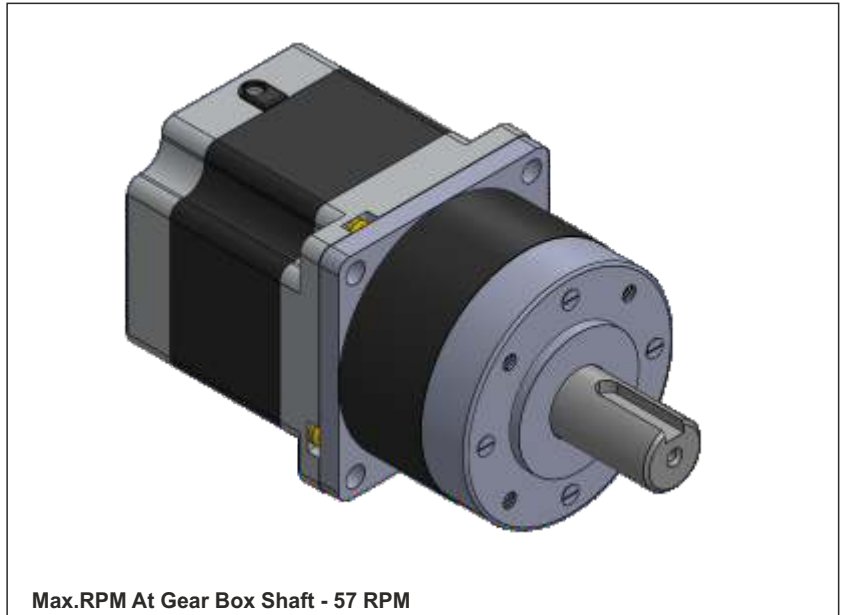

CHARACTERISTICS	
Motor - Bipolar	
Steps per Revolution - 200	
Step Angle - 1.8 degree	
Motor Step Angle Accuracy- \pm 3 Arc Minute	
Dimensions - Refer drawing	
Weight with Gear box - 955 g	
Insulation Class - Class H	
Protection Class - DIN40050 - IP30	
Resistance of Insulation - 100M Ω 500 VDC	
Resistance per phase - 0.95 Ω	
Inductance per phase - 1.8 mH	
Normal current per phase - 2.8 Amp	
Operating Voltage - 24 to 48 VDC	
Stock Temperature - (-10°C to + 70°C)	
Operation Temperature - (-10°C to + 40°C)	
Holding Torque Of Motor - 0.55 Nm	
Holding Torque with gear Box - 9.8 Nm (98 Kgcm)	
Max. Radial Load(12mm from flange) \leq 250N	
Max Shaft axial load \leq 100N	
Radial Play Of Shaft(near to flange) \leq 0.08mm	
Axial Play Of shaft \leq 0.3mm	
Gear Box Ratio - 22.7:1	
Backlash at no load - 1.2 degree	

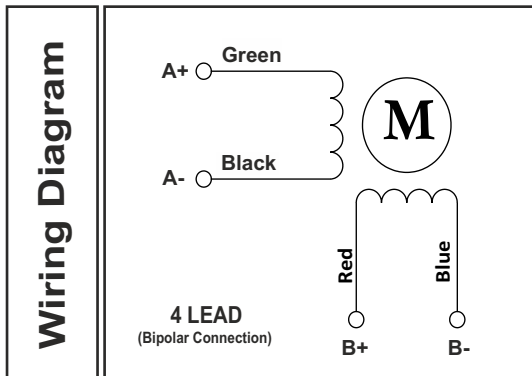
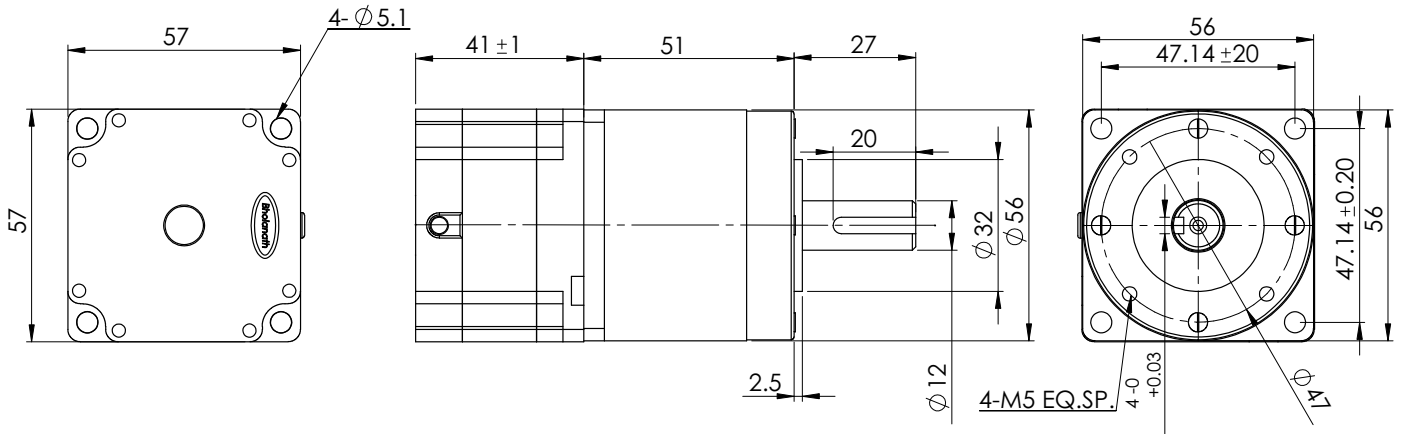
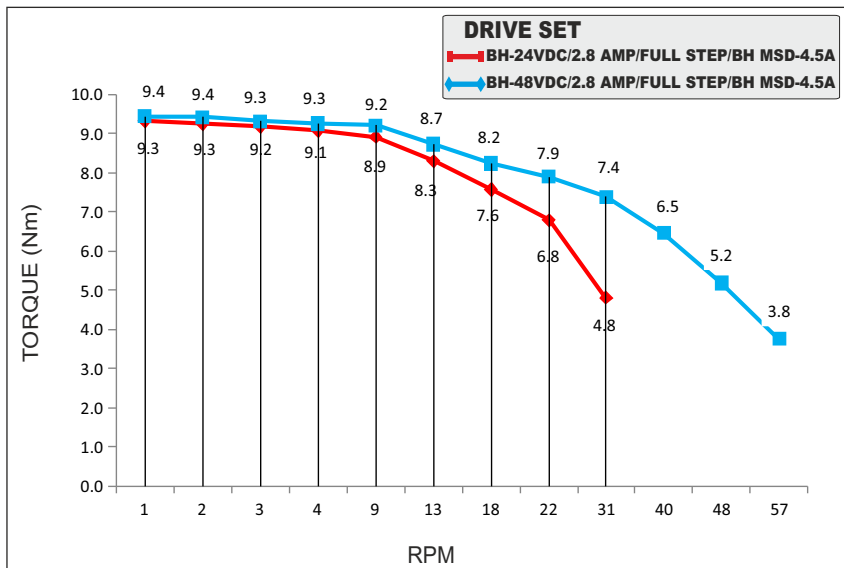

PLANETARY GEAR BOX STEPPER MOTOR - BH57SH41-2804PL-22.7