

**SPECIFICATION SHEET**  
**Bholanath**

**Integrated Captive Linear Actuator  
stepper motor**  
**BH 57 SH 51 - 2804 ICLA (25/50)**  
**(TR8 X 8)**  
**HIGH TORQUE HYBRID**

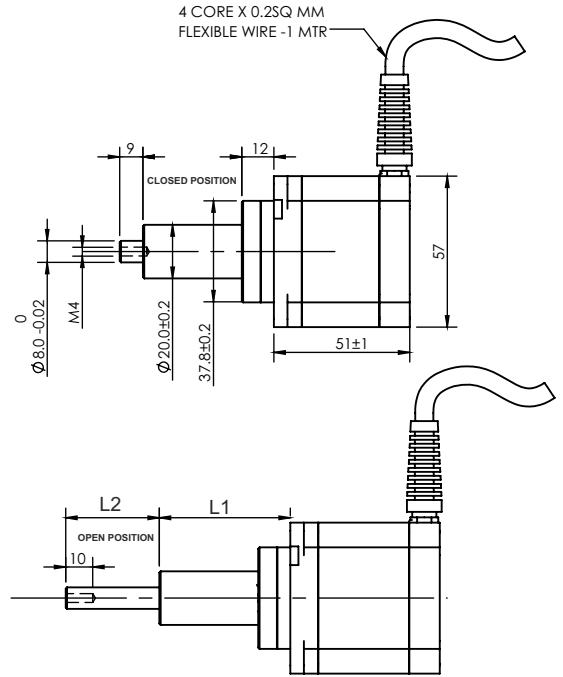
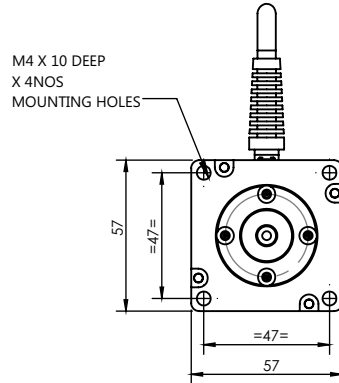

Travel Length (Inch/mm)	L1 (mm)	L2 (mm)
1" / 25mm	50	35
2" / 50mm	85	60

**TECHNICAL DATA**

**CHARACTERISTICS**

- Step Angle - 1.8°
- Step Angle Accuracy - ± 3 Arc Minute
- Insulation Class - H
- Ambient Temperature - (- 20°C to + 50°C)
- Temperature Rise - 80°C Max. ( Rated Current Phase 2 ON )
- Insulation Resistance 100 M Ohms Min.500 VDC
- Dielectric Strength 500 VAC For One Minute

**SPECIFICATION**

**BH 57 SH 51 - 2804 ICLA (25/50)**  
**( TR8X 8 )**

	MODEL	Bipolar
1	Current / phase	A
2	Max horizontal Load Carrying Capacity (Kg)	0.9
3	Permissible Feed Speed (mm/sec)	120
4	Position Accuracy (mm)	0.05
5	Degree of protection (IP rating)	30
6	Linear Step Size at full step (Micron)	40
7	Operating voltage (VDC)	24 to 48
8	Max Axial play (mm)	± 0.05
9	Total Weight of ICLA (Gm)	800

**Note:-** The Load Calculation is Based On Horizontal Movement. For Vertical Movement Kindly Consider Safety Factor Of 0.6 And Motor With Brake.

**Wiring Diagram**

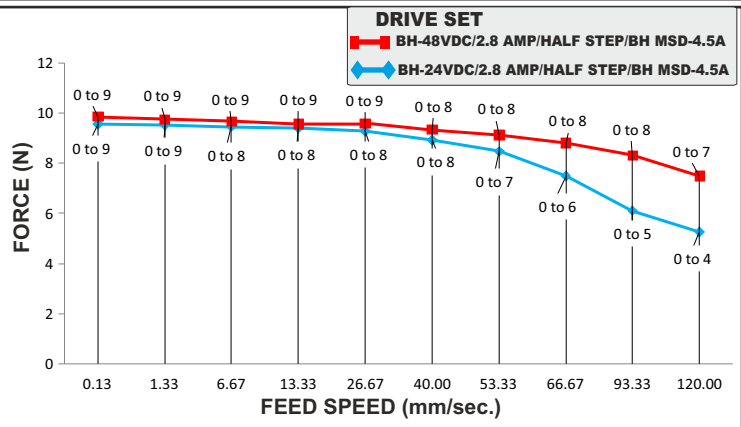
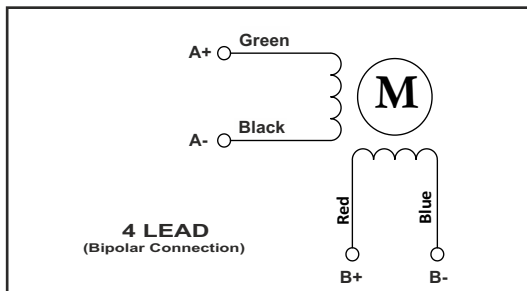

**Bholanath Precision Engineering Pvt.Ltd.**

11,Kembros Ind.Estate , Sonapur Lane , Bhandup (W),Mumbai - 400078.

Telefax/Phone : 25662856/25664338/67993260 Email : support@bholanath.in  
Mobile No : 9920903825/9821671733/9930514603/9819515543/9323166582.