

SPECIFICATION SHEET

Bholanath

Integrated Captive Linear Actuator stepper motor BH 57 SH 100 - 2804 ICLA 25/50 (M10 X 2) HIGH TORQUE HYBRID

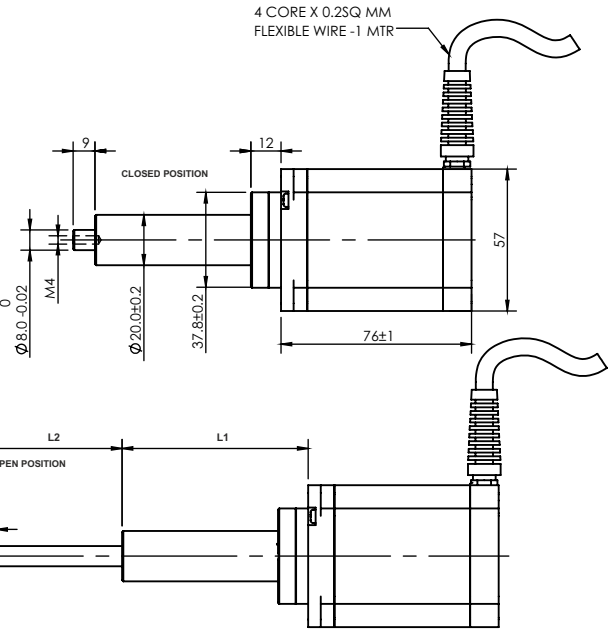
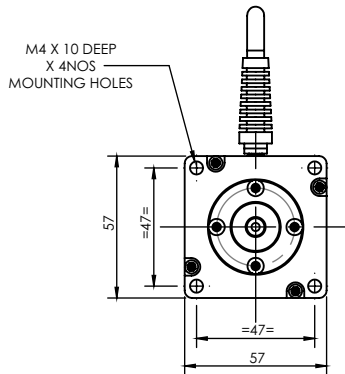
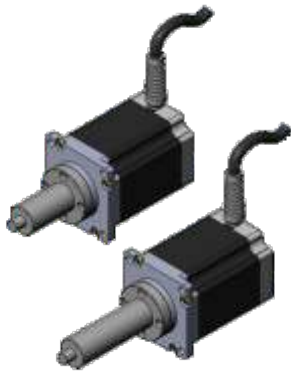

Travel Length (Inch/mm)	L1 (mm)	L2 (mm)
1" / 25mm	49	35
2" / 50mm	74	60

TECHNICAL DATA

CHARACTERISTICS

- Step Angle - 1.8°
- Step Angle Accuracy - ± 3 Arc Minute
- Insulation Class - H
- Ambient Temperature - (- 20°C to + 50°C)
- Temperature Rise - 80° C Max. (Rated Current Phase 2 ON)
- Insulation Resistance 100 M Ohms Min.500 VDC
- Dielectric Strength 500 VAC For One Minute

SPECIFICATION

BH 57 SH 100 - 2804 ICLA 25/50 (M10X2)

	MODEL	Bipolar
1	Current / phase	A
2	Max Load Carrying Capacity (Kg)	9.4
3	Permissible Feed Speed (mm/sec)	30
4	Position Accuracy (mm)	0.05
5	Degree of protection (IP rating)	30
6	Linear Step Size at full step (Micron)	10
7	Operating voltage (VDC)	24 to 48
8	Max Axial play (mm)	± 0.05
9	Total Weight of ICLA (Kg)	2

Note:- The Load Calculation is Based On Horizontal Movement. For Vertical Movement Kindly Consider Safety Factor Of 0.6 And Motor With Brake.

Wiring Diagram

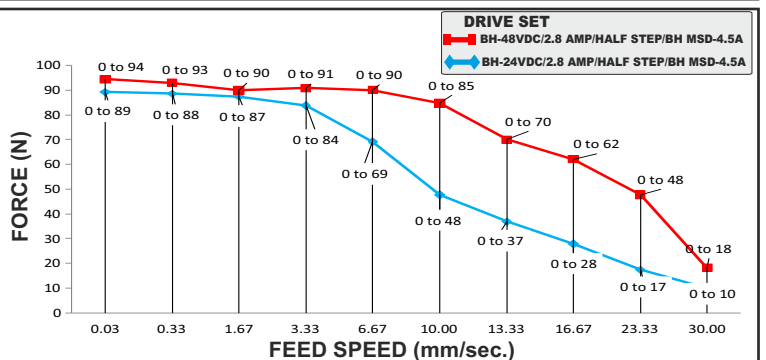
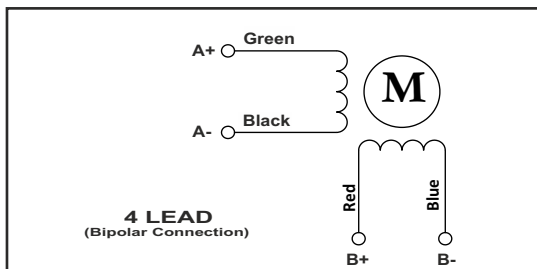

Bholanath Precision Engineering Pvt.Ltd.

11,Kembros Ind.Estate , Sonapur Lane , Bhandup (W),Mumbai - 400078.
 Telefax/Phone : 25662856/25664338/67993260 Email : support@bholanath.in
 Mobile No : 9920903825/9821671733/9930514603/9819515543/9323166582.