

**SPECIFICATION SHEET**  
**Bholanath**

**STEPPER MOTOR**  
**BH57 SH 52 - 2004 AK-16**  
**HIGH TORQUE HYBRID**

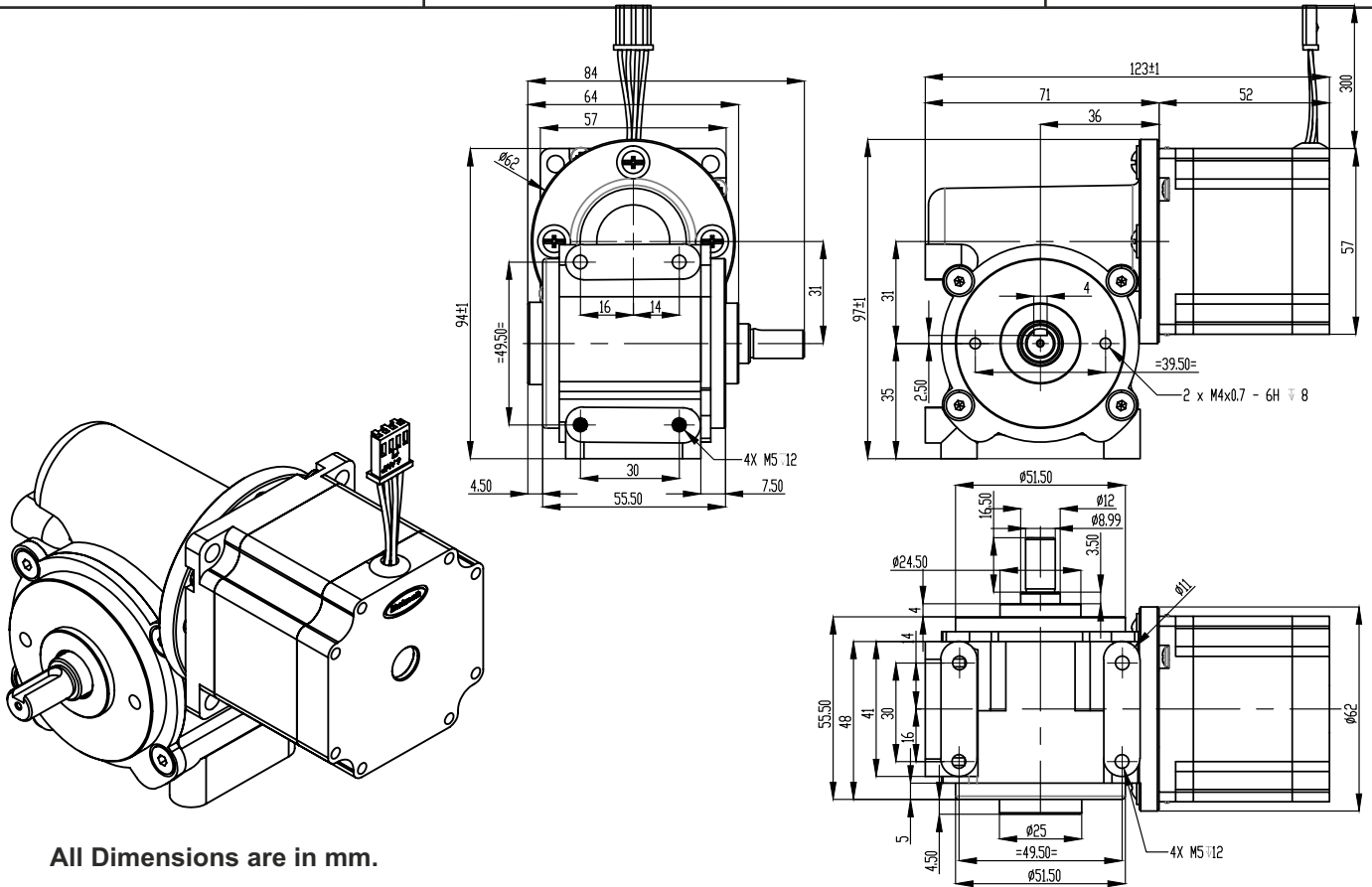

All Dimensions are in mm.

**CHARACTERISTICS**

Motor - Bipolar
Steps per Revolution - 200
Step Angle - 1.8 degree
Motor Step Angle Accuracy - ± 3 Arc Minute
Dimensions - Refer drawing
Weight with Gear box - 1.20 Kg
Insulation Class - Class 155
Protection Class - DIN40050 - IP30
Resistance of Insulation - 100M Ω
Resistance per phase - 0.85 / 0.86 Ω
Inductance per phase - 2.22 / 2.14 mH
Normal current per phase - 2 Amp
Normal Power - 7 Watt
Operating Voltage - 24 - 48 Vdc
Stock Temperature - 10°C To 40°C
Operation Temperature - 10°C To 40°C
Holding Torque for Motor - 0.8 Nm
Holding Torque of gear Box - 12.5 Nm (125Kgcm)
Shaft Axial Play - 0.08 MmmMax(450 G Load)
Shaft Radial Play - 0.02 MmmMax(450 G Load)
Max Shaft Axial Load - ≤ 100N
Max Radial load(12mm from flange) - ≤ 250N
Gear Box Ratio - 16:1
Backlash ≤ 0.8 Degree
Rotor Inertia of Motor - 273.13 GM-CM <sup>2</sup>
Rotor Inertia of Gearbox - 137.75 GM-CM <sup>2</sup>

**Wiring Diagram**

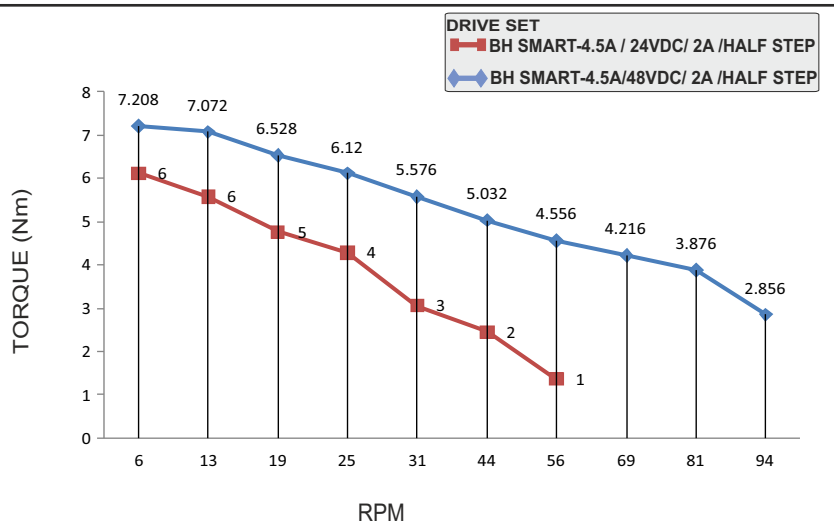
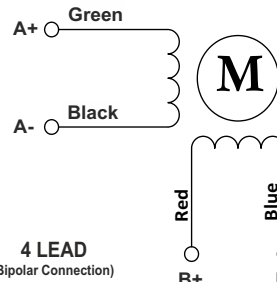

**GEAR BOX STEPPER MOTOR - BH57SH52-2004AK-16**