

SPECIFICATION SHEET
Bholanath

X-Y AXIS POSITIONING TABLE
BHBS-LLHS-X-YSLIDE-150 (M)

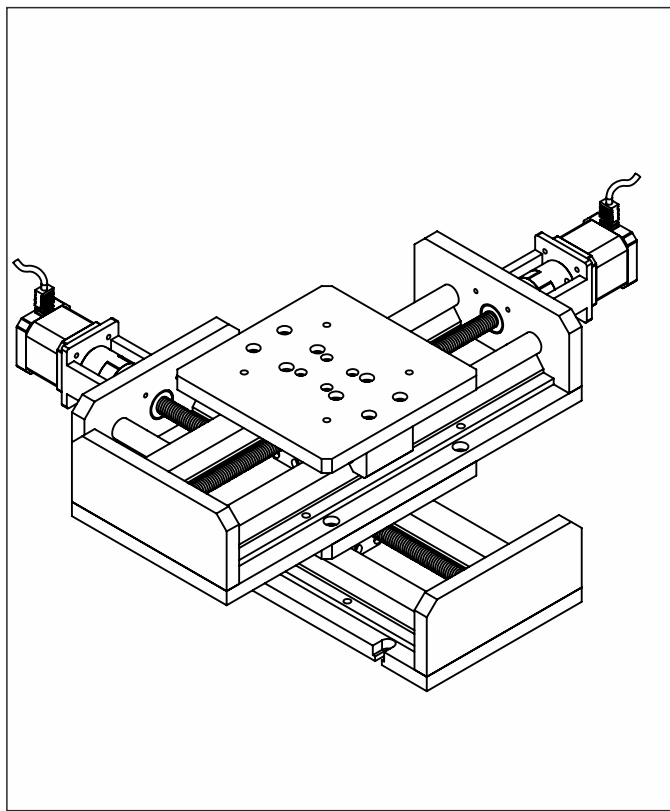

HIGH PRECISION X -Y AXIS POSITIONING TABLE-LINEAR BALL SCREW SLIDE

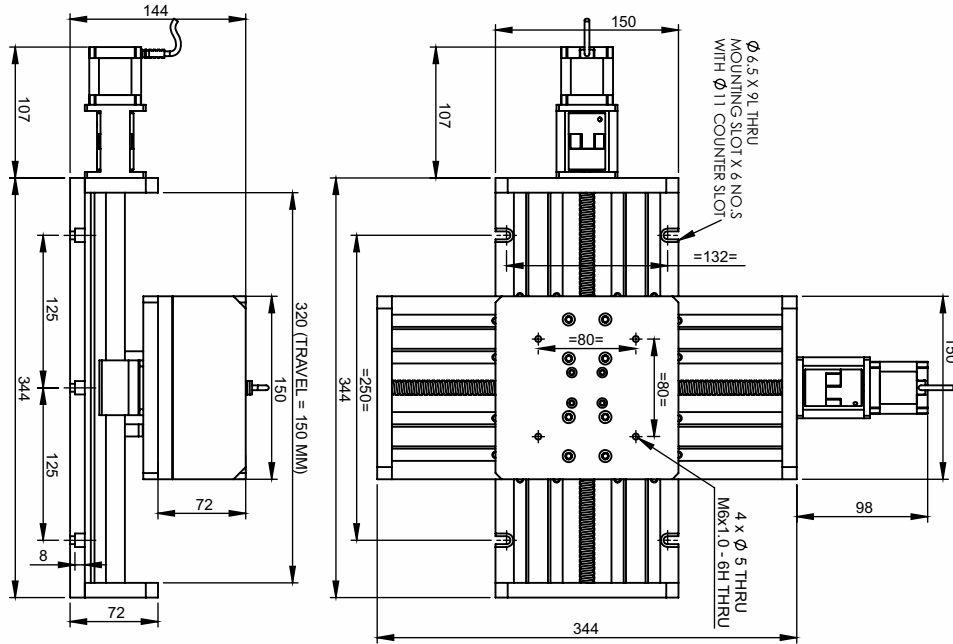

TECHNICAL DATA

SPECIFICATION Model No BHBS-LLHS-X-YSLIDE-150 (M)

1	Maximum load carrying capacity(kg)	0 to 15
2	Permissible Feed Speed of X-Y	0 to 166 mm/sec
3	Positioning Accuracy (mm)	≤ 0.02
4	Degree Of protection	IP 40
5	Total Weight of slide (KG)	11

Note:- The Load Calculation is Based On Horizontal Movement. For Vertical Movement Kindly Consider Safety Factor Of 0.6 And Motor With Brake.

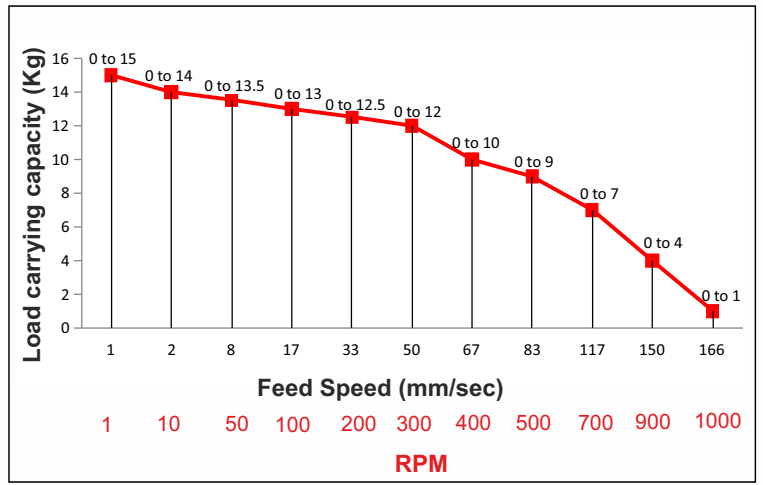

Bholanath Precision Engineering Pvt.Ltd.

11,Kembros Ind.Estate , Sonapur Lane , Bhandup (W),Mumbai - 400078.
Telefax/Phone : 25662856/25664338/67993260 Email : support@bholanath.in
Mobile No : 9920903825/9821671733/9930514603/9819515543/9323166582.