

# Bholanath

Precision Engineering Pvt.Ltd.

**Bholanath**®

COMMITTED TO PRECISION  
www.bholanath.in



## *User's Manual* Integrated Drive Step Servo BHSS - 100W-I

**Note:-** Integrated Drive Step servo & motor are matched pair with **BH-48VDC** power supply

### Office Address

### **Bholanath Precision Engineering Pvt.Ltd.**

11,Kembros Industrial Estate,Near Asian Paint Company,  
Sonapur Lane,Bhandup (West),Mumbai - 400078,India.

### FACTORY ADDRESS

Plot No - 1, Gut No - 203 , Dahagaon , Vasind (West) , Wada Link Road ,  
Off Mumbai Nashik Road ,  
Opposite Jindal Steel Factory ,  
Taluka - Shahpur , District - Thane - 421 302 ,  
Maharashtra State , India.

### **Contact Us**

### Phone No : -

+91 - 9821671733  
+91 - 9920903825  
+91 - 9930514603  
+91 - 9323166582

91 - 22 - 25664338 /25662856 / 67993260

Email : support@bholanath.in

► Overview ( Integrated Drive Step Servo )	3
1. BHSS 100W-I - Step Servo	5
2. Performance Indicator	6
2.1. Electrical feature	6
2.2. Working environment	6
3. Port Definition	7
3.1 Input/output port	7
3.2 Switch	7
3.3 Power port	7
4. Control Signal Connection	8
4.1 Input Signal	8
4.2 Output Signal	8
4.3 Input signal timing diagram	9
4.4 Dip switch setting	9
5. Alarm Diagnosis	10



Bholanath Step Servo motors are closed loop stepping systems - high speed (>2000 RPM) stepper motors with incremental optical encoders and digital drives.

Incremental optical encoders ( 1000 PPR and 2500 PPR ) feedback with new generation digital drives,Bholanath Step Servo motors get the reliability of servo motors.

Bholanath Step Servo motors are good replacement of servo motors (25 Watts to 1500 Watts), the price being much lower than servo motors.

Bholanath Step Servo motors give high speed performance of servo motors with accurate feedback and micro stepping accuracy of stepper motors with feedback.

Bholanath Step Servo motors give better holding torque's(complete stand still position).

### ► Comparison between Bholanath Step Servo BHSS - 400 W with 400 Watt servo motor.

As can be seen from the graph,the Bholanath Step Servo motor torque equals servomotor torque at 2000 RPM.Thus for applications up to 2000 RPM,Bholanath Step Servo motor can easily be used.At lesser RPM,say at 1000 RPM,the Bholanath Step Servo motor gives 50% more torque than servo,giving the user much better performance.

The Step Servo Motor Driver has automatic current adjustments as per load,resulting in low heat / generation,thereby giving high efficiency.

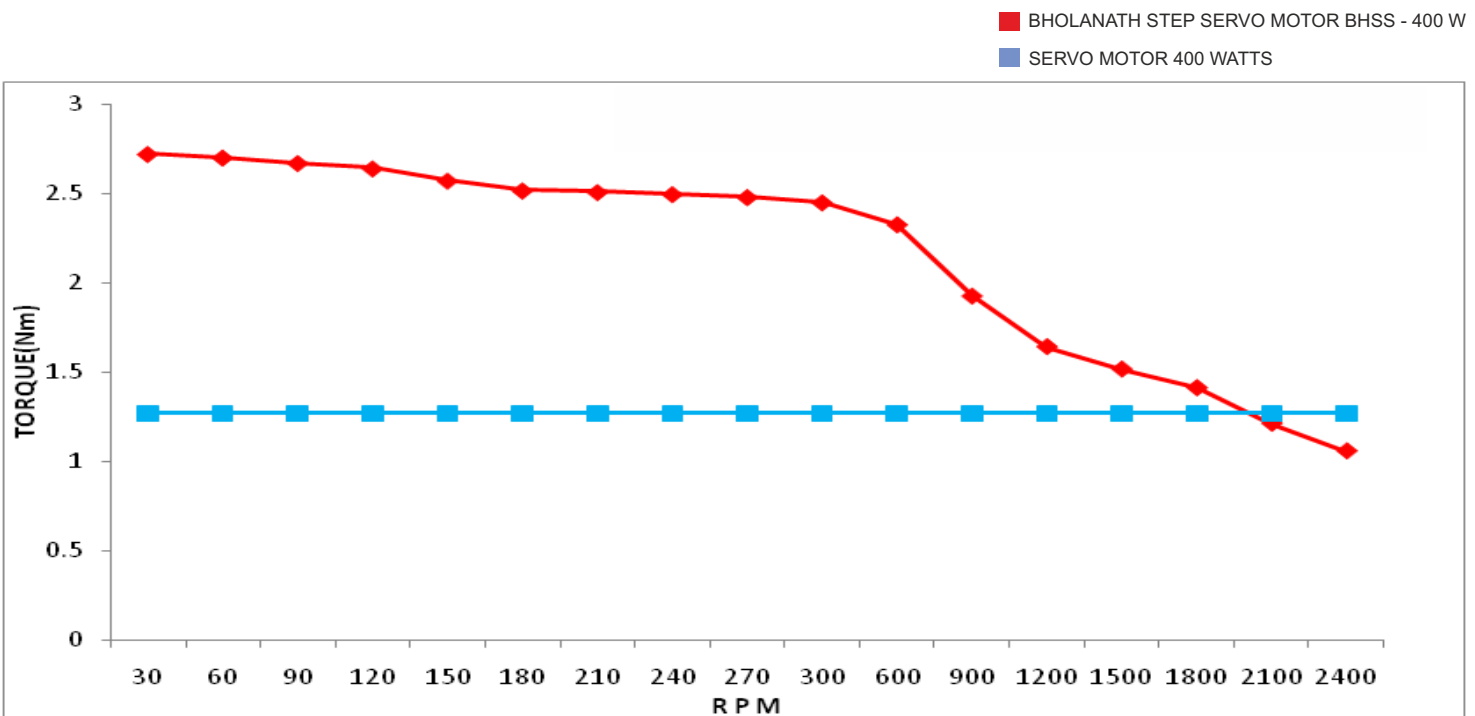

# 1 Overview

## 1.1 Product introduction

**Bholanath** integrated stepper motor drive uses a new generation of 32-bit DSP control technology and power angle control technology, the maximum speed can be up to 3000rpm and above. The high-speed torque attenuation is much lower than ordinary open-loop drive, which can greatly enhance stepper motor high-speed performance and effectively reduce motor heat and vibration, thereby enhancing the machine's processing efficiency and accuracy.

The use of load-based current control technology can effectively reduce the motor heat, extend motor life. Drive built-in alarm and position ready output signal are used for host computer to monitor and control. Position deviation alarm function would ensure the safe operation of processing equipment.

## 1.2 Features

- New generation of 32-bit DSP technology
- Maximum pulse response frequency 200KHZ
- Small torque attenuation with speed up to 2000 RPM
- Built-in alarm output, easy to monitor and control
- Intelligently adjust current, reduce vibration, noise and heat, increased 35% efficiency
- Pulse / direction (PU / DR) control
- Voltage range: DC18V to 50V
- Excellent high speed performance and rigidity, perfectly combine servo and stepper advantages
- Over-voltage, under-voltage, over-current protection
- Integrated drive motor design
- Easy installation, small dimension, simple wiring

## 1.3 Applications

Mainly used in wire stripping machines, marking machines, cutting machines, plotters, medical equipment and automation equipment and instruments.



Closed Loop Stepping System which includes High Speed (>2000 RPM) Stepper Motors with Incremental Optical Encoders, Digital Drives .

**SUITABILITY** - The BHSS - 100 W-I Step Servo is comparable to 100 Watts Servo Motor upto 2000 RPM. The Step - Servo Motor BHSS - 100 W-I gives more torque at lower RPM's thus giving a better performance than 100 Watts Servo Motors as seen in the graph.

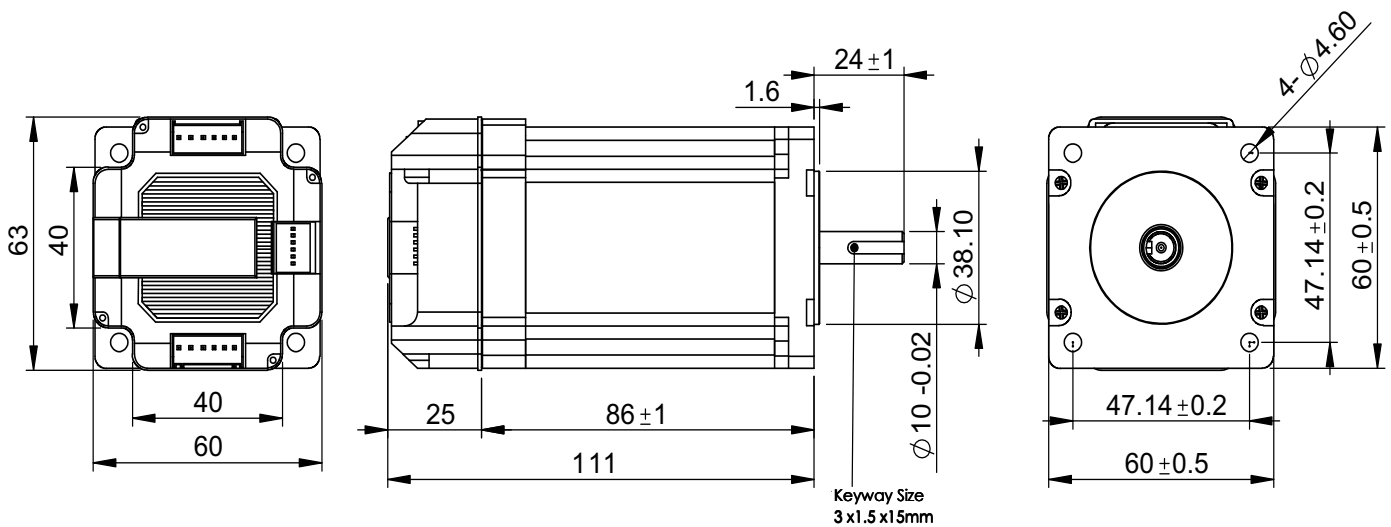

## TECHNICAL DATA

### Characteristics

Power Input - BH-48VDC
Encoder Options - 1000 PPR
Motor - Bipolar Hybrid Stepper Motor
Step Angle - 1.8 Degree
Degree Of Protection - DIN 40050 IP 60 / IP 65
Insulation Class - H
Weight - 1.85 Kg
Current Per Phase - 2.8 A
Torque - 3.1 Nm - 0.32Nm
RPM - 0 - 2000
Stock Temperature - ( - 10° C to + 70° C )
Operation Temperature - ( - 10° C to + 40° C )
Shaft Axial Play - 0.08 Max.Play (450 G Load)
Shaft Radial Play - 0.02 Max.Play (450 G Load)
Max. Radial Force - 220 N (20 MM from Front Flange)
Max. Axial Force - 60 N (20 MM from Front Flange)

- BHOANATH STEP SERVO MOTOR BHSS - 100 W-I
- SERVO MOTOR 100 WATTS

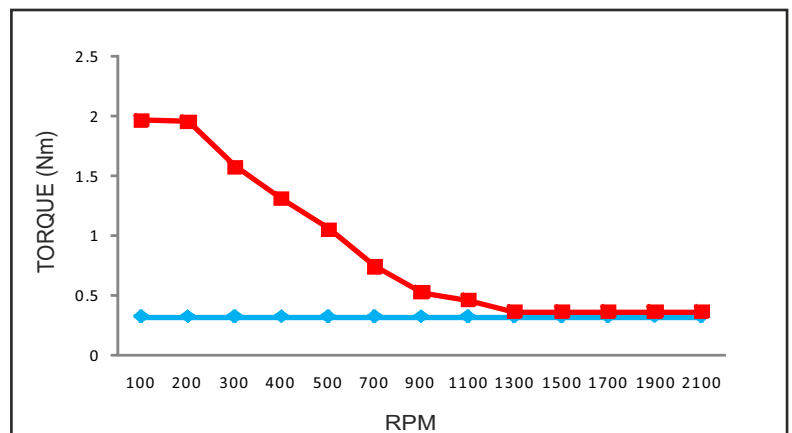

### Motor Options Available -

- Standard Model - I
- With Low Backlash Planetary Gearbox - PL
- With Helical Gear Box - HL
- CE Certificate - N - STANDARD/CE - CERTIFIED
- ORDERING CODE** - BHSS- 100 W-I - 1000 - IP 60-N

## 2 Performance indicators

### 2.1 Electrical features

Spec.	Bholanath integrated step servo drive			
	Min value	Typical value	Max value	Unit
Output current	0	-	4.0	A
Input voltage	18	24	50	Vdc
Logic input current	7	10	16	mA
Logic input voltage	-	5	24	V
Pulse frequency	0	-	200	kHz
Insulation resistance	100	-	-	MΩ

### 2.2 Working environment

Cooling	Cooling fin	
Working environment	Environment	Keep away from other heating equipment as far as possible. Avoid dust, oil mist, corrosive gas, strong vibration, prohibit combustible gas and conductive dust
	Temperature	0°C~50°C
	Humidity	40—90%RH (No condensation)
	Vibration	10~55Hz/0.15mm
Storage temperature	-20°C~+80°C	

### 3 Port definition

#### 3.1 Input / output port

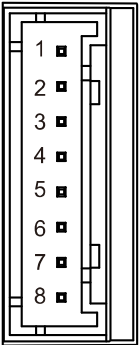
Port	PIN	Mark	Name	Function
	1	PU+	Pulse input +	5V-24V, current limit resistor is needed when the voltage is higher than 5V.
	2	PU-	Pulse input -	
	3	DR+	Direction input +	
	4	DR-	Direction input -	
	5	MF+	Enable input +	
	6	MF-	Enable input -	
	7	ALM+	Alarm signal output positive	The alarm signal is valid for over-current, over-voltage, under-voltage or position deviation. ALM+ connect to controller input+, ALM- connect to controller input-.
	8	ALM-	Alarm signal output negative	

#### 3.2 Switch

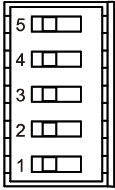
Port	PIN	Mark	Name	Function
	1	SW1	Switch	SW1: Motor rotate direction setting
	2	SW2		SW2-5: Microstep setting
	3	SW3		
	4	SW4		
	5	SW5		

#### 3.3 Power port

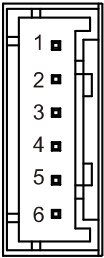
Port	PIN	Mark	Name	Function
	1	NC	Reserve	Reserve
	2	NC		
	3	NC		
	4	NC		
	5	GND	Power port	DC: 24V~72V
	6	+DC		

## 4 Control signal connection

### 4.1 Input signal

All signals are isolated by optic-isolation in order to ensure that the built-in high-speed optocoupler can be reliably turned on. The current capability of the control signal should be at least 15mA. Optocoupler current-limiting resistor is inserted into the driver. When the input signal voltage is higher than 5V, external resistor is needed for current limit.

Current limiting resistor selection:

When the controller signal output level is

+5V:  $R1=0, R2=0$

+12V:  $R1=510\Omega, R2=820\Omega$

+24V:  $R1=1.2K\Omega, R2=1.8K\Omega$

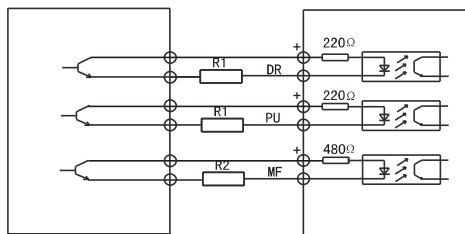

Controller Drive  
**Differential connection**

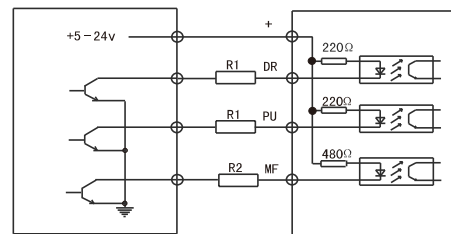

Controller Drive  
**Common anode connection**

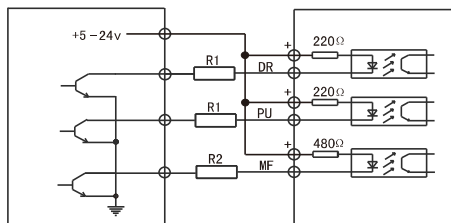

Controller Drive

**Independent common anode connection**

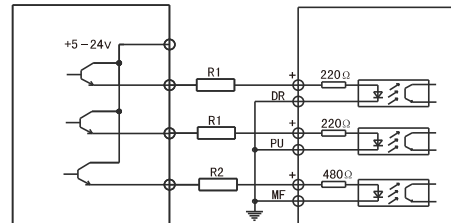

Controller Drive

**Independent common cathode connection**

### 4.2 Output signal

Driver output signal is output through isolated optocoupler, the drive current is 50mA.

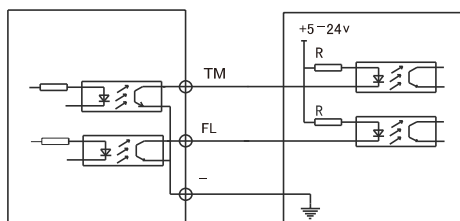

Drive Actuator  
**Common cathode connection**

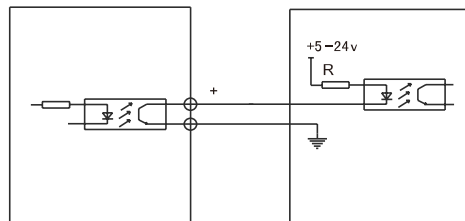

Drive Actuator  
**Independent connection**



### 4.3 Input signal timing diagram

In order to avoid wrong actions and deviations, PU, DR and MF should meet certain requirements, as shown below:

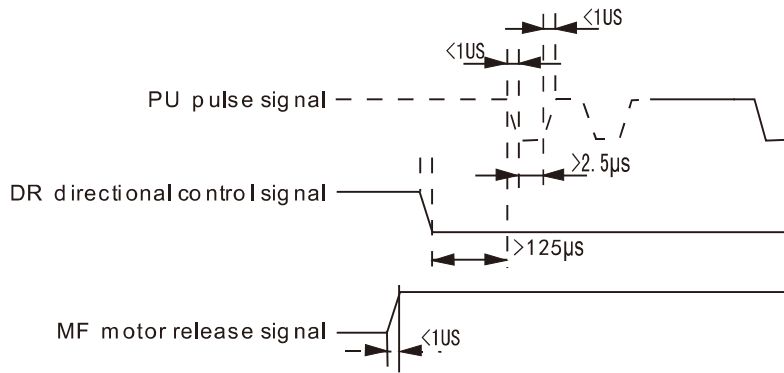

Input signal timing diagram

### 4.4 DIP switch settings

integrated stepper motor drive use 5-bit DIP switch to set microstep and motor rotation direction, described in detail as follows:

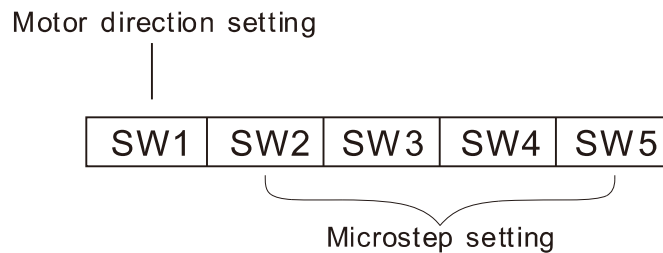

DIP switch combination

- **Motor direction setting**

This bit can be used to set motor rotation direction as shown in the table:

SW1	Motor rotation direction
OFF	CW
ON	CCW

SW1 sets motor direction. When it is OFF, the motor turns clockwise (CW). When it is ON, the motor rotates counterclockwise (CCW).

- **Microstep setting**



4-bit DIP switch, 16 current microstep options.

Microstep (Pulse/rev)	SW2	SW3	SW4	SW5
400	ON	ON	ON	ON
800	OFF	ON	ON	ON
1600	ON	OFF	ON	ON
3200	OFF	OFF	ON	ON
6400	ON	ON	OFF	ON
12800	OFF	ON	OFF	ON
25600	ON	OFF	OFF	ON
51200	OFF	OFF	OFF	ON
1000	ON	ON	ON	OFF
2000	OFF	ON	ON	OFF
4000	ON	OFF	ON	OFF
5000	OFF	OFF	ON	OFF
8000	ON	ON	OFF	OFF
10000	OFF	ON	OFF	OFF
20000	ON	OFF	OFF	OFF
40000	OFF	OFF	OFF	OFF

YAKO can customize the microstep parameters, the range is 400~40000 (Pulse / rev).

## 5 Alarm diagnosis

integrated stepper motor has 4 kinds of alarm information, the alarm indicator flashing several times according to the alarm code, the specific alarm code and treatment as shown in the following table.

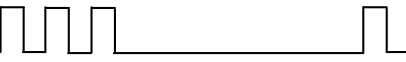
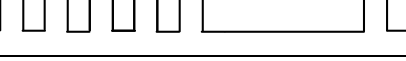
Alarm code	Alarm message	Indicator	Reset
Err1: 0x01	Overcurrent or short circuit between phases		Re-power to reset
Err2: 0x02	Power supply voltage high		Lock motor / reset automatically
Err3: 0x03	Power supply voltage low		Lock motor / reset automatically
Err5: 0x05	Position deviation		Re-power to reset