

**SPECIFICATION SHEET**  
**Bholanath**

**STEPPER MOTOR**  
**BH86 SH 156 - 6204 PL-10**  
**HIGH TORQUE HYBRID**

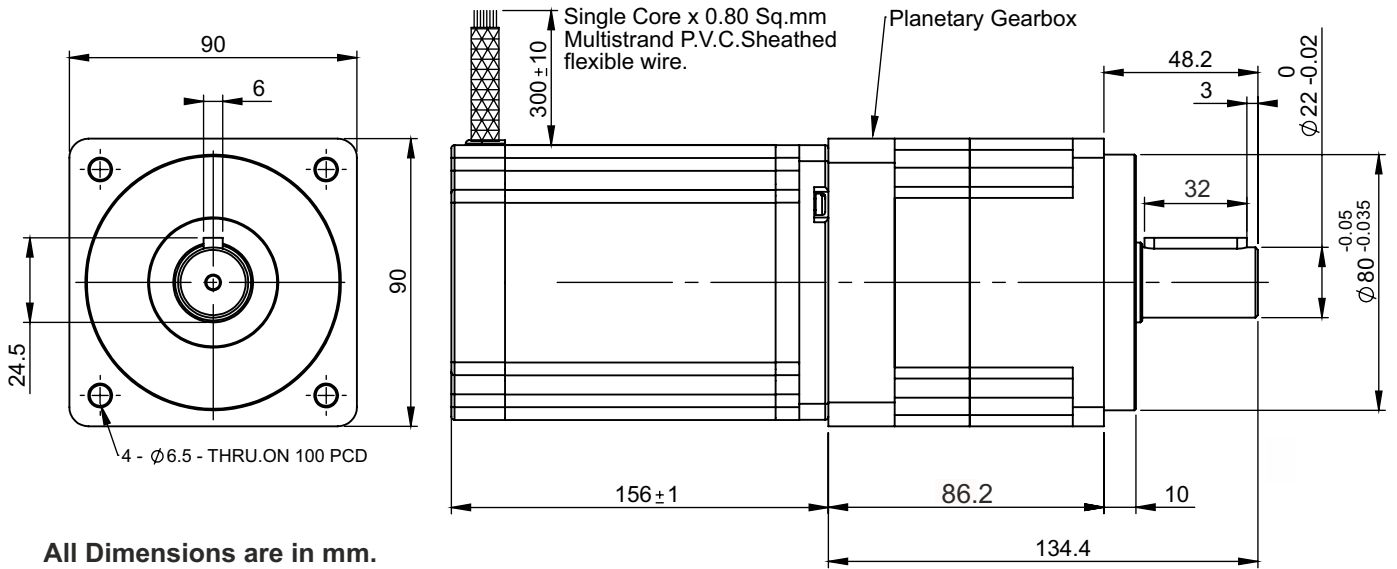

**Wiring Diagram**

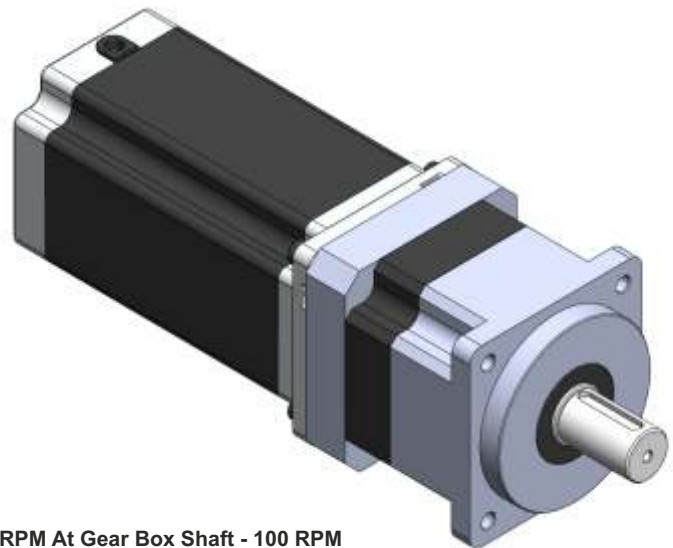
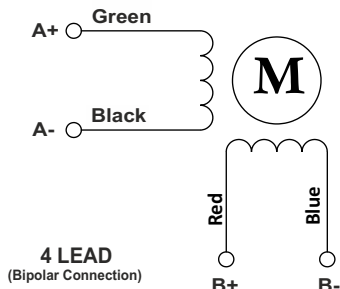

Max.RPM At Gear Box Shaft - 100 RPM

**CHARACTERISTICS**

Motor - Bipolar
Steps per Revolution - 200
Step Angle - 1.8 degree
Dimensions - Refer drawing
Weight with Gear box - 9.0 Kg
Insulation Class - Class H
Protection Class - DIN40050 - IP30
Resistance of Insulation - 100M $\Omega$ 500 VDC
Resistance per phase - 0.85 $\Omega$
Inductance per phase - 9.4 mH
Normal current per phase - 6.2 Amp
Operating Voltage - 24 to 140 VDC
Stock Temperature - (-10°C to + 70°C)
Operation Temperature - (-10°C to + 40°C)
Holding Torque Of Motor - 18.0 Nm
Holding Torque with gear Box - 180.0 Nm (1800 Kgcm)
Max Radial load(12mm from flange) - $\leq$ 910N
Max Shaft Axial Load - $\leq$ 580N
Gear Box Ratio - 10:1
Backlash Arcmin - Precision 10

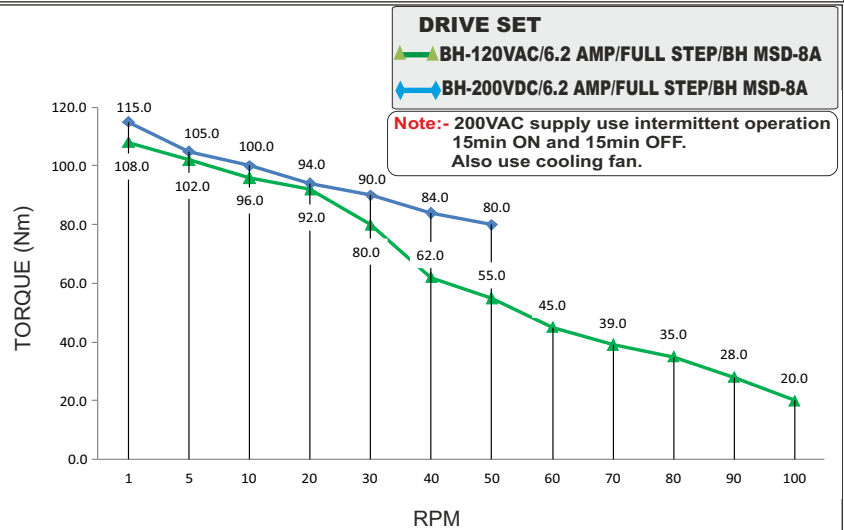

**PLANETARY GEAR BOX STEPPER MOTOR - BH86SH156-6204PL-10**