

SPECIFICATION SHEET
Bholanath

STEPPER MOTOR
BH86 SH 156 - 6004 PL-20
HIGH TORQUE HYBRID

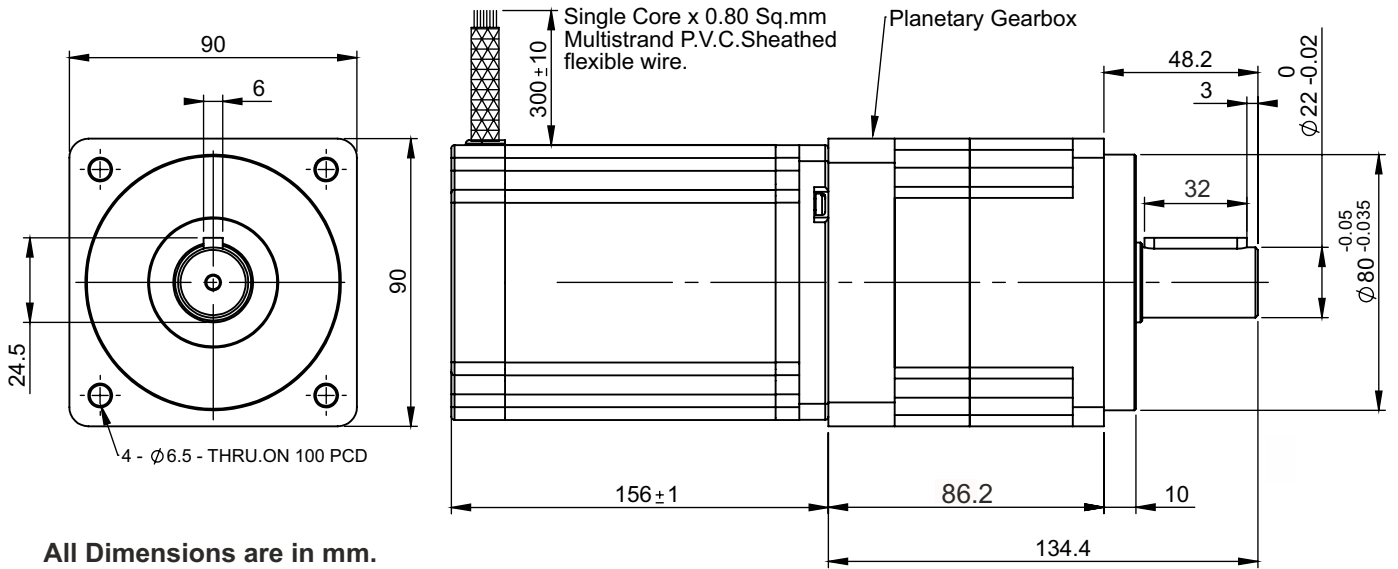

All Dimensions are in mm.

Wiring Diagram

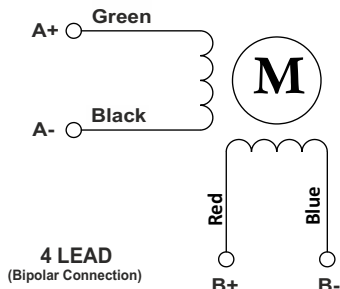

4 LEAD
(Bipolar Connection)

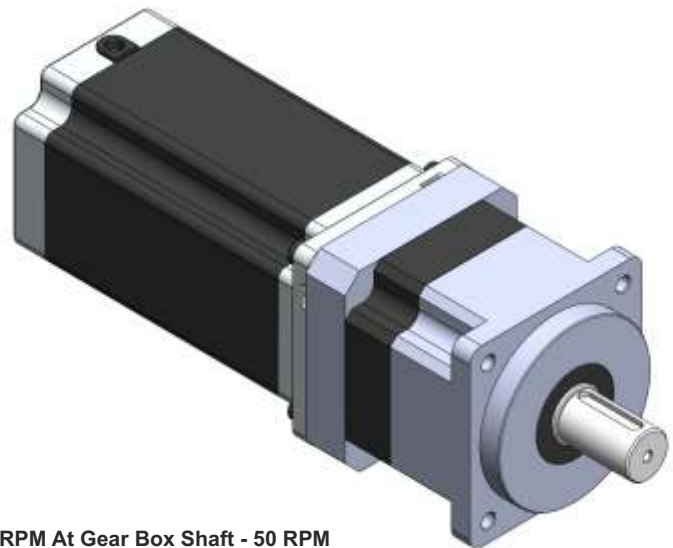

Max.RPM At Gear Box Shaft - 50 RPM

CHARACTERISTICS

Motor - Bipolar
Steps per Revolution - 200
Step Angle - 1.8 degree
Dimensions - Refer drawing
Weight with Gear box - 9.0 Kg
Insulation Class - Class H
Protection Class - DIN40050 - IP30
Resistance of Insulation - 100M Ω 500 VDC
Resistance per phase - 0.80 Ω
Inductance per phase - 10.5 mH
Normal current per phase - 6.2 Amp
Operating Voltage - 24 to 140 VDC
Stock Temperature - (-10°C to + 70°C)
Operation Temperature - (-10°C to + 40°C)
Holding Torque Of Motor - 12.8 Nm
Holding Torque with gear Box - 256.0 Nm (2500 Kgcm)
Max Radial load(12mm from flange) - ≤ 910N
Max Shaft Axial Load - ≤ 580N
Gear Box Ratio - 20:1
Backlash Arcmin - Precision 10

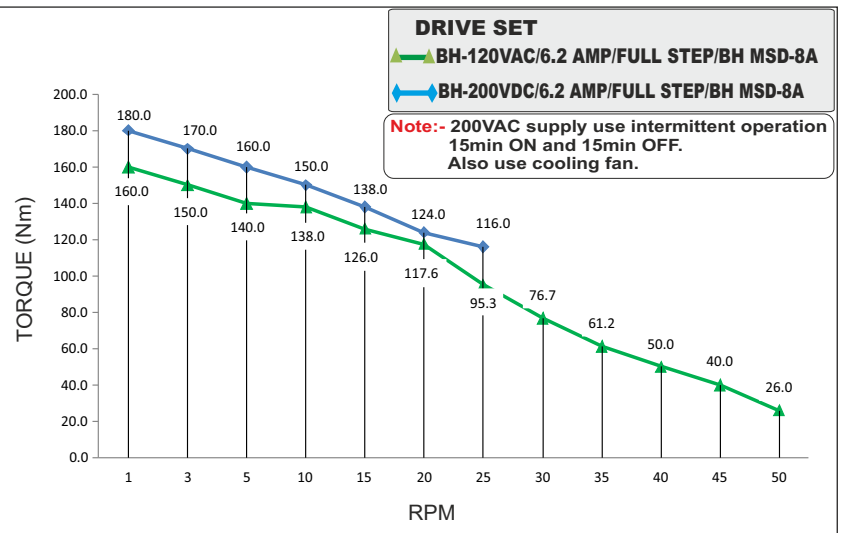

PLANETARY GEAR BOX STEPPER MOTOR - BH86SH156-6004PL-20