

SPECIFICATION SHEET
Bholanath

STEPPER MOTOR
BH57 SH 76 - 2804 PL
HIGH TORQUE HYBRID

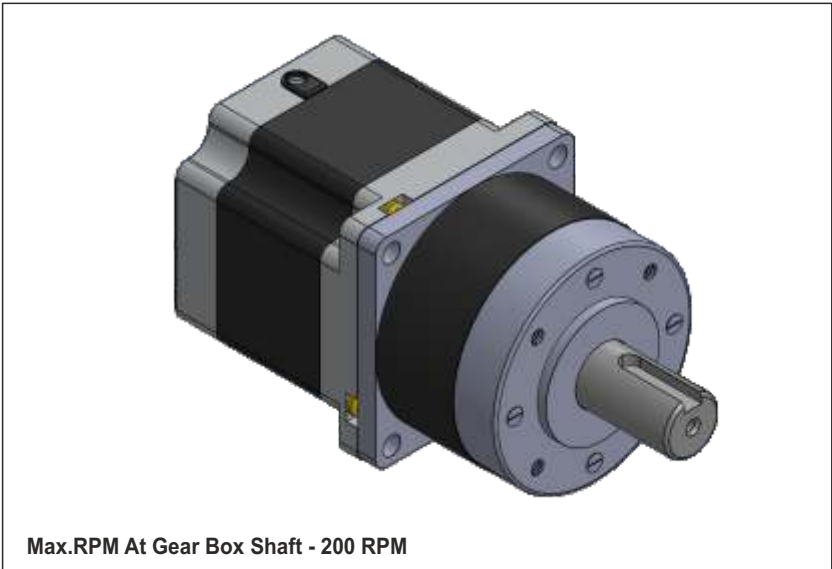
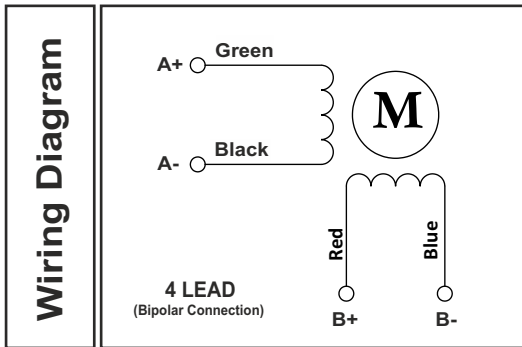
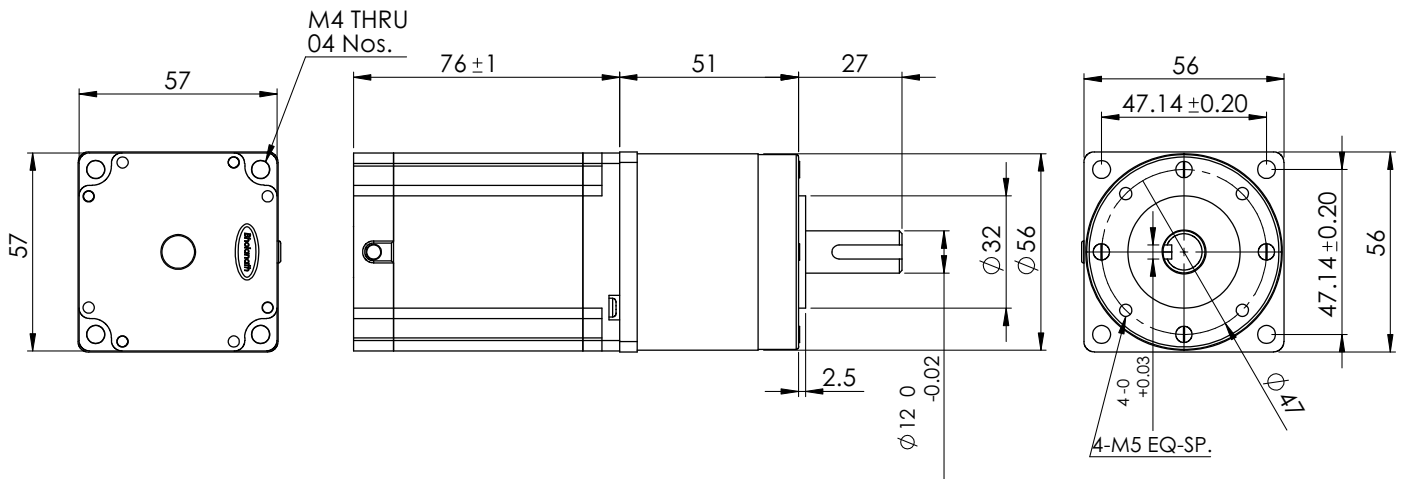

CHARACTERISTICS

Motor - Bipolar
Steps per Revolution - 200
Step Angle - 1.8 degree
Motor Step Angle Accuracy- ± 3 Arc Minute
Dimensions - Refer drawing
Weight with Gear box - 1.6 Kg
Insulation Class - Class H
Protection Class - DIN40050 - IP30
Resistance of Insulation - 100M Ω 500 VDC
Resistance per phase - 1.2 Ω
Inductance per phase - 4.5 mH
Normal current per phase - 2.8 Amp
Operating Voltage - 24 to 42 VDC
Stock Temperature - (-10°C to + 70°C)
Operation Temperature - (-10°C to + 40°C)
Holding Torque Of Motor - 1.89 Nm
Holding Torque with gear Box - 7.2 Nm (72 Kgcm)
Max. Radial Load(12mm from flange) ≤ 250 N
Max Shaft axial load ≤ 100 N
Radial Play Of Shaft(near to flange) ≤ 0.08 mm
Axial Play Of shaft ≤ 0.3 mm
Gear Box Ratio - 4.3:1
Backlash at no load - 1.5 degree

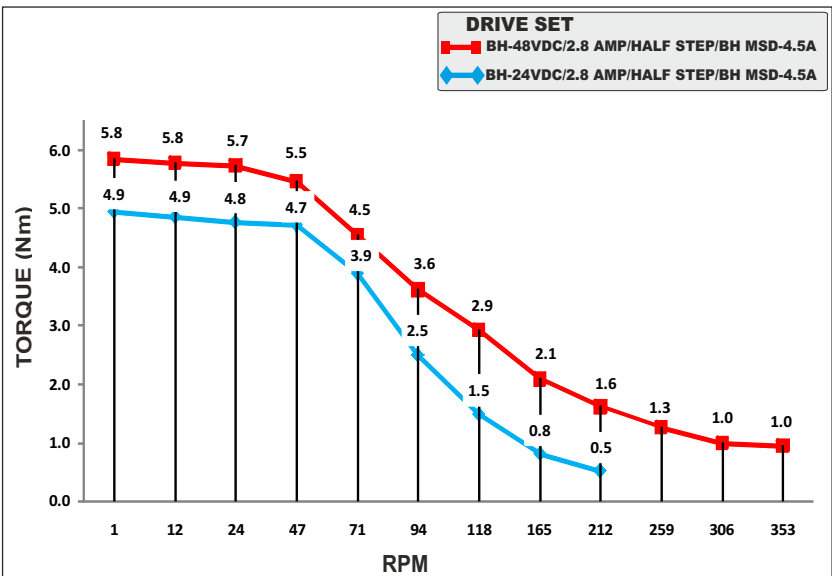

PLANETARY GEAR BOX STEPPER MOTOR - BH57SH76-2804PL