

SPECIFICATION SHEET
Bholanath

STEPPER MOTOR
BH86 SH 96 - 2004AKS
HIGH TORQUE HYBRID

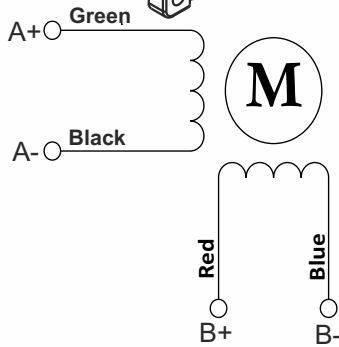
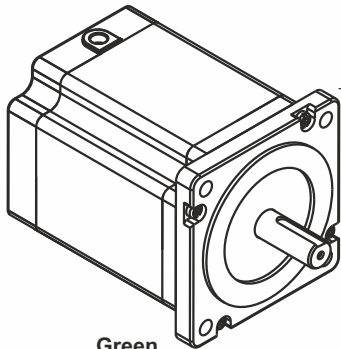
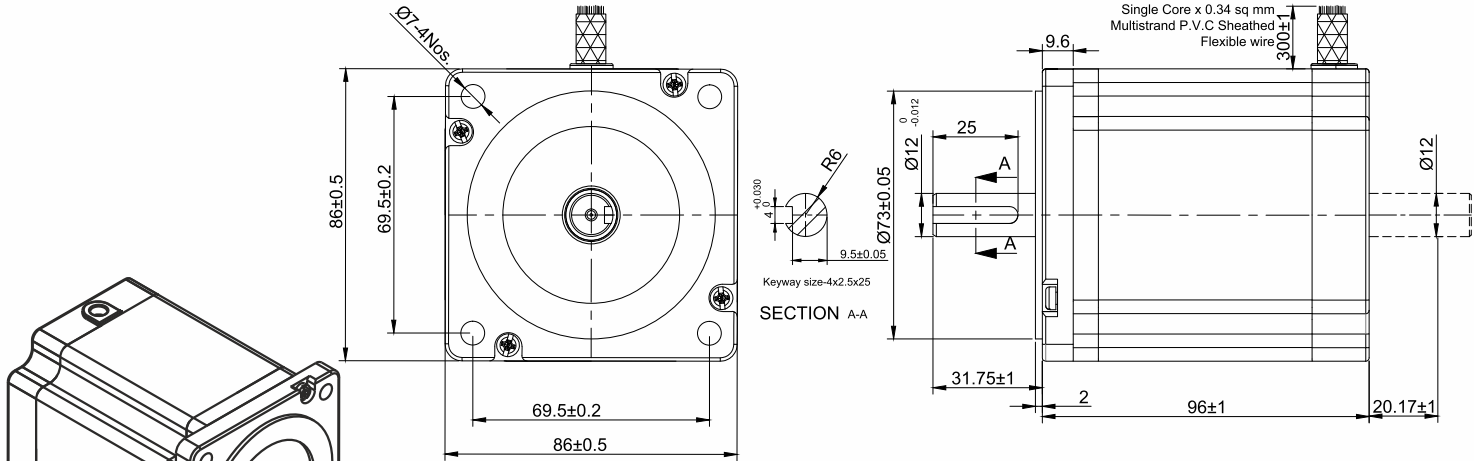

TECHNICAL DATA

SPECIFICATION BH86SH96 - 2004 AKS			
	MODEL		Bipolar
1	Rated Voltage	V	7.52
2	Current / Phase	A	2
3	Resistance / Phase	± 10% Ω	3.76
4	Inductance / Phase	± 20% mH	30
5	Holding Torque	Nm	7.44
6	Rotor Inertia	G-CM ²	2700
7	Weight	KG.	3.1
8	No of Lead	N ⁰	4
9	Operating Voltage	VDC	48 - 170
9	Operating Voltage	VAC	34 - 120

CHARACTERISTICS

Step Angle - 1.8°
Step Angle Accuracy - ± 3 Arc Minute
Insulation Class - H
Ambient Temperature - -20°C + 50°C
Temperature Rise - 80°C Max. (Rated Current Phase 2 ON)
Insulation Resistance 100 M Ohms Min.500 VDC
Dielectric Strength 820 VAC For One Minute
Shaft Radial Play 0.02 Max. Play (450 G Load)
Shaft Axial Play 0.08 Max. Play (450 G Load)
Max.Radial Force 220 N (20MM From Front Flange)
Max.Axial Force 60 N

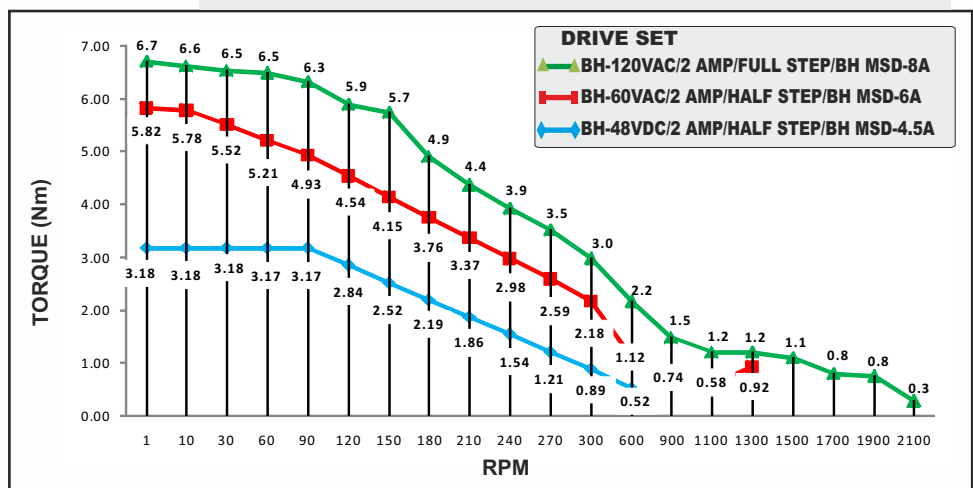

STEPPER MOTOR -BH86SH96-2004AKS



Bholanath Precision Engineering Pvt.Ltd.

COMMITTED TO PRECISION

11,Kembros Ind.Estate , Sonapur Lane , Bhandup (W),Mumbai - 400078.

BHOLANATH COOL STEPPERS™

Telefax/Phone : 25662856/25664338/67993260 Email : support@bholanath.in

Mobile No : 9920903825/9821671733/9930514603/9819515543/9323166582.