

**SPECIFICATION SHEET**  
**Bholanath**

**STEPPER MOTOR**  
**BH 57 SH 51-2804 A**  
**HIGH TORQUE HYBRID**

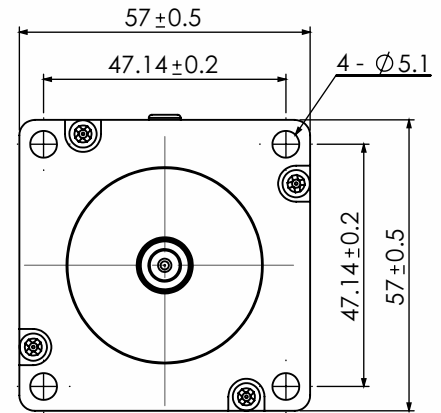
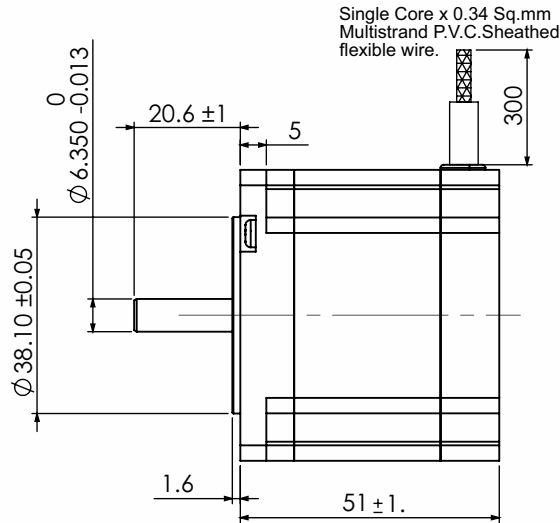
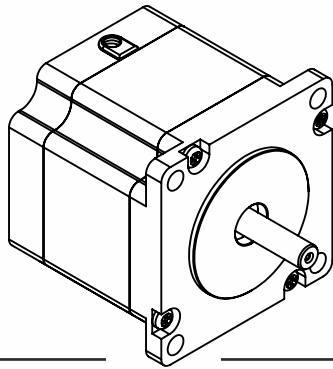

**TECHNICAL DATA**

**CHARACTERISTICS**

Step Angle - 1.8°
Step Angle Accuracy - ± 3 Arc Minute
Insulation Class - H
Ambient Temperature - - 20°C + 50°C
Temperature Rise - 80°C Max. ( Rated Current Phase 2 ON )
Insulation Resistance 100 M Ohms Min.500 VDC
Dielectric Strength 500 VAC For One Minute
Shaft Radial Play 0.02 Max. Play ( 450 G Load )
Shaft Axial Play 0.08 Max. Play ( 450 G Load )
Max.Radial Force 75 N ( 20MM From Front Flange )
Max.Axial Force 15 N

**SPECIFICATION**

**BH57SH51 - 2804 A**

MODEL	Bipolar	
1 Rated Voltage	V	2.46
2 Current / Phase	A	2.8
3 Resistance / Phase	± 10% Ω	0.88
4 Inductance / Phase	± 20% mH	2.2
5 Holding Torque	Nm	1.01
6 Rotor Inertia	G-CM <sup>2</sup>	275
7 Weight	KG.	0.65
8 No of Lead	N <sup>0</sup>	4
9 Operating Voltage	VDC	24 - 48

**Wiring Diagram**

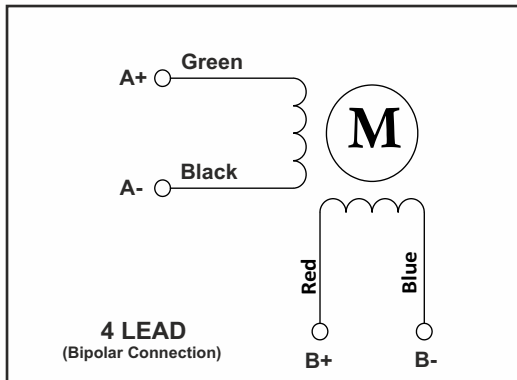

**DRIVE SET**

■ BH-48VDC/2.8 AMP/HALF STEP/BH MSD-4.5A  
◆ BH-24VDC/2.8 AMP/HALF STEP/BH MSD-4.5A

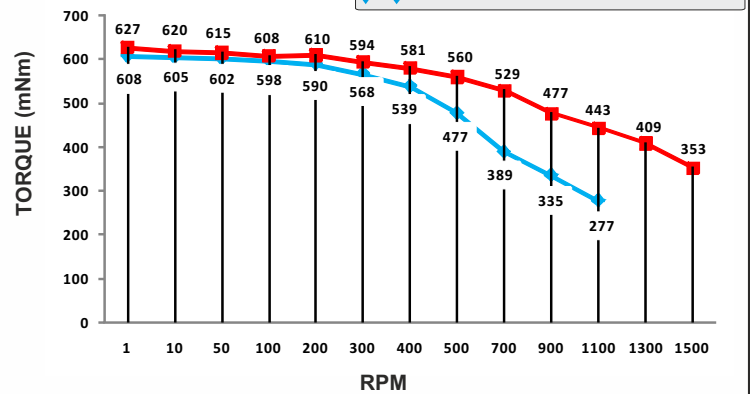

**MOTOR MODEL - BH57SH51-2804A**



**Bholanath Precision Engineering Pvt.Ltd.**

11,Kembros Ind.Estate , Sonapur Lane , Bhandup (W),Mumbai - 400078.

Telefax/Phone : 25662856/25664338/67993260 Email : support@bholanath.in

Mobile No : 9920903825/9821671733/9930514603/9819515543/9323166582.