

SPECIFICATION SHEET
Bholanath

STEPPER MOTOR
BH42 SH 60-0854 A-B12
HIGH TORQUE HYBRID

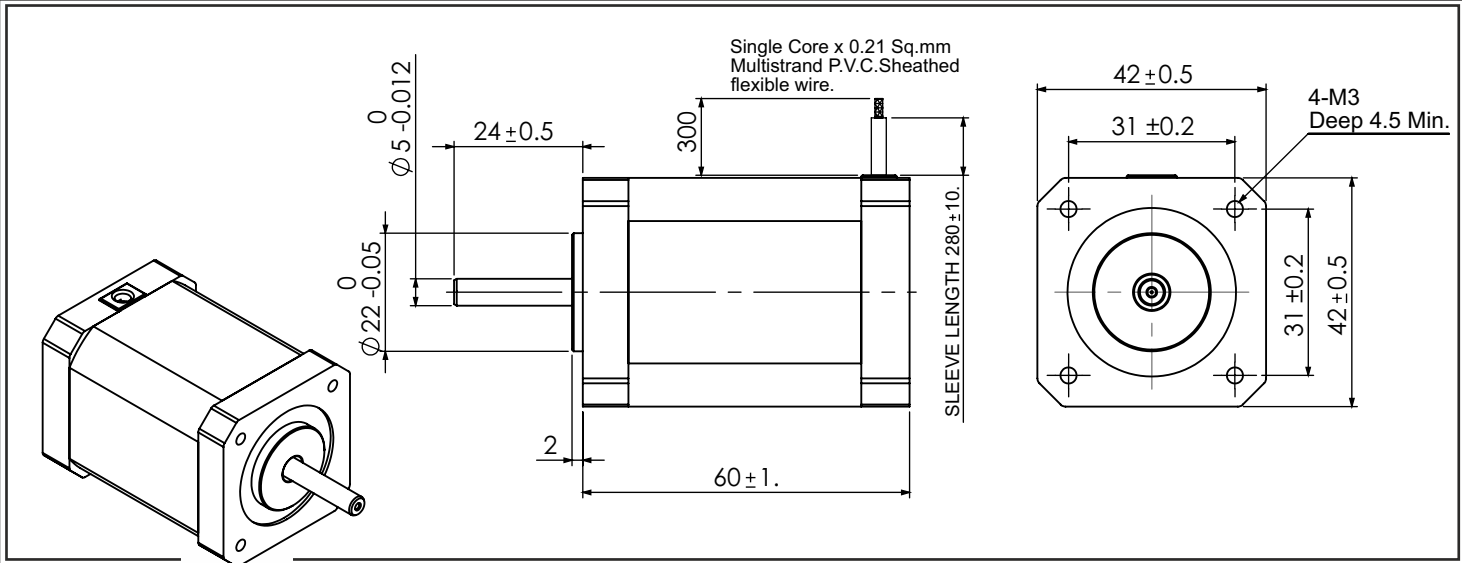

TECHNICAL DATA

CHARACTERISTICS

Step Angle - 1.8°
Step Angle Accuracy - ± 3 Arc Minute
Insulation Class - H
Ambient Temperature - - 20°C + 50°C
Temperature Rise - 80°C Max. (Rated Current Phase 2 ON)
Insulation Resistance 100 M Ohms Min.500 VDC
Dielectric Strength 500 VAC For One Minute
Shaft Radial Play 0.02 Max. Play (450 G Load)
Shaft Axial Play 0.08 Max. Play (450 G Load)
Max.Radial Force 28 N (20MM From Front Flange)
Max.Axial Force 10 N

SPECIFICATION

BH42SH60 - 0854A-B12

MODEL	Bipolar	
1 Rated Voltage	V	10.2
2 Current / Phase	A	0.85
3 Resistance / Phase	± 10% Ω	12
4 Inductance / Phase	± 20% mH	17.23
5 Holding Torque	Nm	0.48
6 Rotor Inertia	G-CM ²	102
7 Weight	KG.	0.487
8 No of Lead	N ⁰	4
9 Operating Voltage	VDC	24 - 50

Wiring Diagram

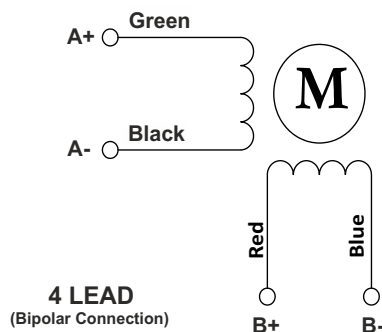

DRIVE SET

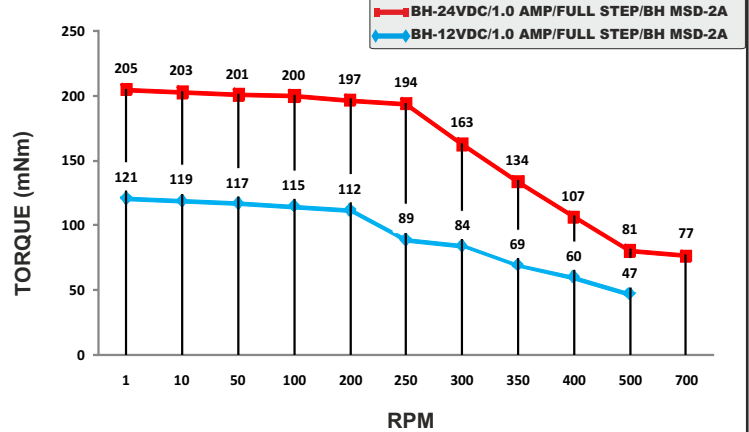

MOTOR MODEL -BH 42 SH60-0854A-B12



Bholanath Precision Engineering Pvt.Ltd.

11,Kembros Ind.Estate , Sonapur Lane , Bhandup (W),Mumbai - 400078.
Telefax/Phone : 25662856/25664338/67993260 Email : support@bholanath.in
Mobile No : 9920903825/9821671733/9930514603/9819515543/9323166582.