

**SPECIFICATION SHEET**  
**Bholanath**

**INTEGRATED DRIVE STEPPER MOTOR**  
**BH42 SH 38-1684 A-I**  
**HIGH TORQUE HYBRID**

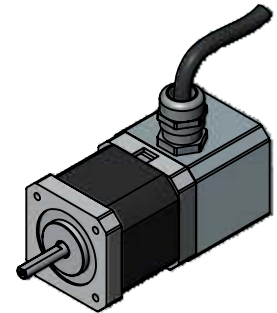
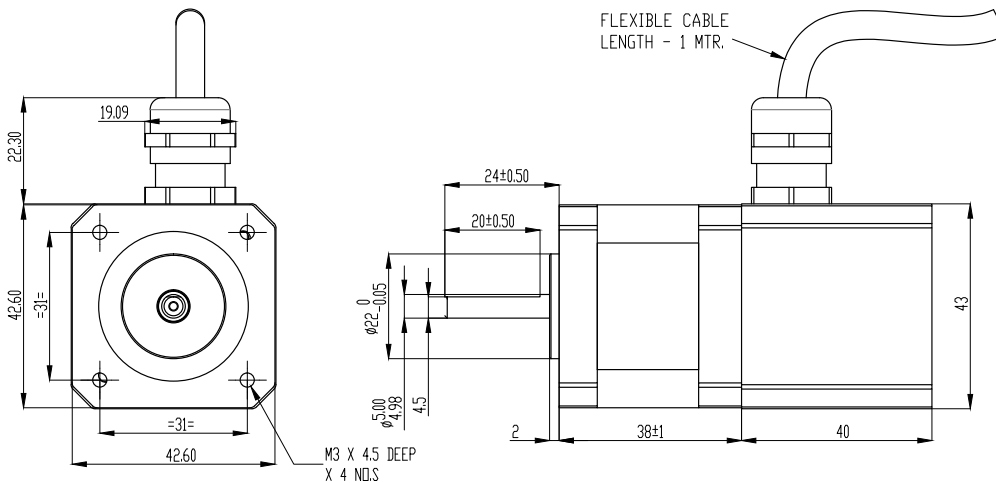

**TECHNICAL DATA**

**CHARACTERISTICS**

Step Angle - 1.8°
Step Angle Accuracy - ± 3 Arc Minute
Insulation Class - H
Ambient Temperature - - 20°C + 50°C
Temperature Rise - 80°C Max. ( Rated Current Phase 2 ON )
Insulation Resistance 100 M Ohms Min.500 VDC
Dielectric Strength 500 VAC For One Minute
Shaft Radial Play 0.02 Max. Play ( 450 G Load )
Shaft Axial Play 0.08 Max. Play ( 450 G Load )
Max.Radial Force 28 N ( 20MM From Front Flange )
Max.Axial Force 10 N

**SPECIFICATION**

SPECIFICATION		BH42SH38 -1684A	
	MODEL	Bipolar	
1	Rated Voltage	V	3.44
2	Current / Phase	A	1.68
3	Resistance / Phase	± 10% Ω	2.05
4	Inductance / Phase	± 20% mH	3.28
5	Holding Torque	Nm	0.36
6	Rotor Inertia	G-CM <sup>2</sup>	54
7	Weight	KG.	0.27
8	No of Lead	N <sup>0</sup>	4
9	Operating Voltage	VDC	12 - 24

**Wiring Details.**

Yellow	→	Pulse -
Green	→	Dir -
Blue	→	ENA-
White	→	Com.
Red	→	+ VDC
Black	→	- VDC

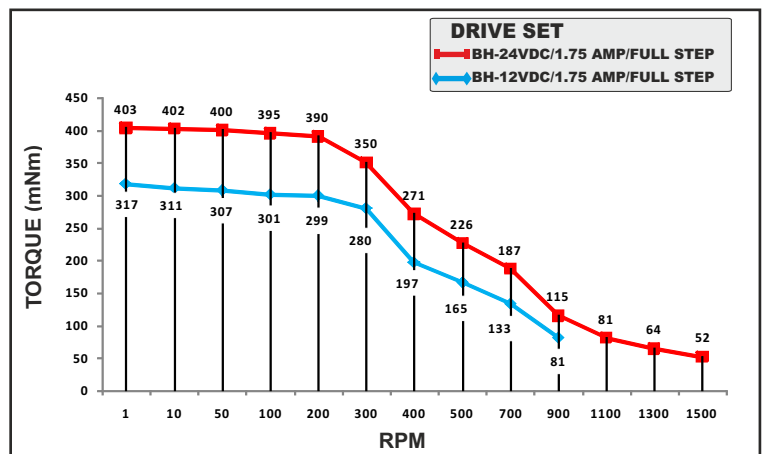

**MOTOR MODEL - BH42SH38-1684A**



**Bholanath Precision Engineering Pvt.Ltd.**

11,Kembros Ind.Estate , Sonapur Lane , Bhandup (W),Mumbai - 400078.  
Telefax/Phone : 25662856/25664338/67993260 Email : support@bholanath.in  
Mobile No : 9920903825/9821671733/9930514603/9819515543/9323166582.