

SPECIFICATION SHEET
Bholanath

STEPPER MOTOR
BH86 SH 118 - 4004AKS-CE
HIGH TORQUE HYBRID

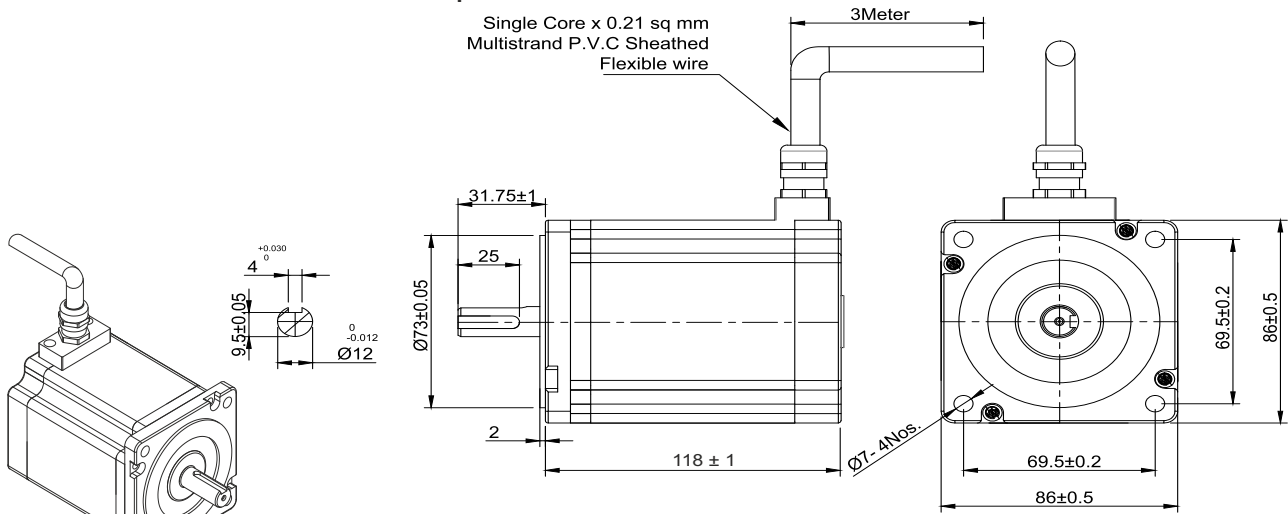

TECHNICAL DATA

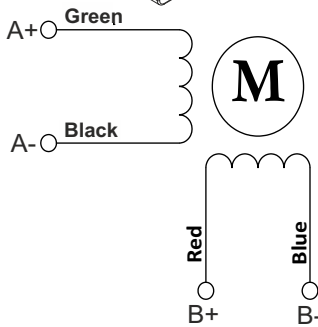

Wiring Diagram

SPECIFICATION BH 86SH 118 - 4004 AKS-CE			
	MODEL		Bipolar
1	Rated Voltage	V	3.08
2	Current / Phase	A	4
3	Resistance / Phase	± 10% Ω	0.77
4	Inductance / Phase	± 20% mH	4.5
5	Holding Torque	Nm	9.19
6	Rotor Inertia	G-CM ²	2700
7	Weight	KG.	4
8	No of Lead	N ^o	4
9	Operating Voltage	VDC	48 - 170
10	Operating Voltage	VAC	34 - 120

CHARACTERISTICS

Step Angle - 1.8°
Step Angle Accuracy - ± 3 Arc Minute
Insulation Class - H
Ambient Temperature - - 20
Temperature Rise - 80°C Max. °C + 50°C (Rated Current Phase 2 ON)
Insulation Resistance 100 M Ohms Min.500 VDC
Dielectric Strength 820 VAC For One Minute
Shaft Radial Play 0.02 Max. Play (450 G Load)
Shaft Axial Play 0.08 Max. Play (450 G Load)
Max.Radial Force 220 N (20MM From Front Flange)
Max.Axial Force 60 N

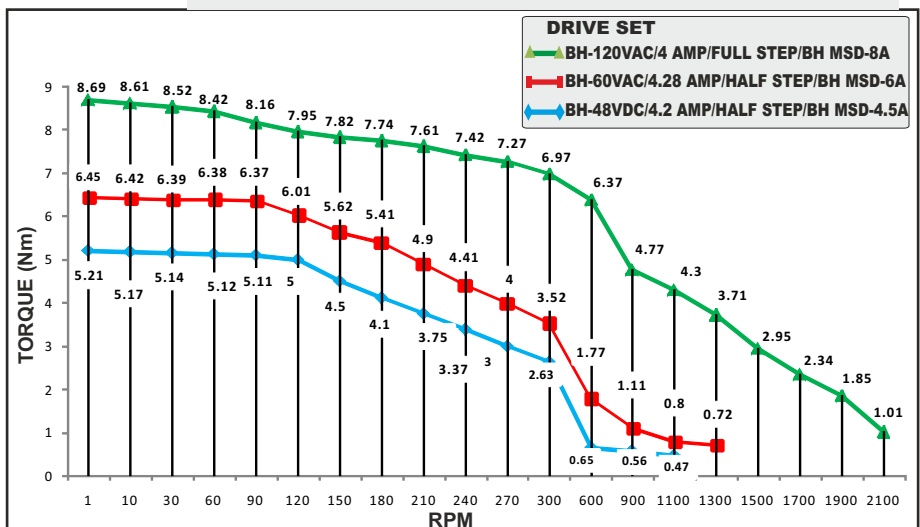

STEPPER MOTOR - BH86SH118- 4004 AKS-CE



Bholanath Precision Engineering Pvt.Ltd.

11, Kembros Ind.Estate , Sonapur Lane , Bhandup (W), Mumbai - 400078.
 Telefax/Phone : 25662856/25664338/67993260 Email : support@bholanath.in
 Mobile No : 9920903825/9821671733/9930514603/9819515543/9323166582.