

Drilling and Thread Tapping is an important operation in every workshop. For mass production operator gets tired doing repetitive up down z-axis motion with force. Due to operator fatigue the production suffers.

Bholanath Precision has overcome this with simple Z-Axis automation.

BH-DM-01-M is an 13mm standard new drill machine on which helical geared stepper motor is mounted on the Z axis, due to which the up down motion becomes automatic.

To watch videos kindly click on below you tube links.

Youtube link-

<https://www.youtube.com/watch?v=9N0ilWz6ADg&feature=youtu.be>

https://www.youtube.com/watch?v=NiRaVS_ygz0&feature=youtu.be

<https://www.youtube.com/watch?v=TOCJEUW6g2k&feature=youtu.be>

BH-DMA-01-M comes with state of art control panel which consists of stepper driver controller BH-SDC-01, stepper driver **BH-Smart-4.5A**, power supply and necessary wiring and switches.

The controller **BH-SDC-01-N** is simple controller manufactured by Bholanath, the controller language is simple English and very easy to learn and operate.

To watch the controller operating videos kindly click on below you tube links.

Youtube link-

<https://www.youtube.com/watch?v=mA7aqmB9eCo&feature=youtu.be> Part 1

<https://www.youtube.com/watch?v=wizLndJLTeA&feature=youtu.be> Part 2

<https://www.youtube.com/watch?v=dXrevwVmH50&feature=youtu.be> Part 3

A Foot switch is connected to the controller for easy operation so that operators hands remains free and homing limit switch is provided.

Features of the machine -

1. Drilling size and depth as per data sheet
2. Peck drilling is very simple by programming
3. Drilling Feed speeds settable by programming
4. High speed Reaming
5. Limit switch for homing
6. Direct Tapping with controller (No attachment needed)
7. Coolant tank optional available at extra cost
8. K.M Panchal-KMP Machine is used in this model.



Tapping Calculation :- to tapping kindly see below calculation

Tapping Feed rate = O/P RPM Of Spindle X pitch of tap

60

MM/SEC

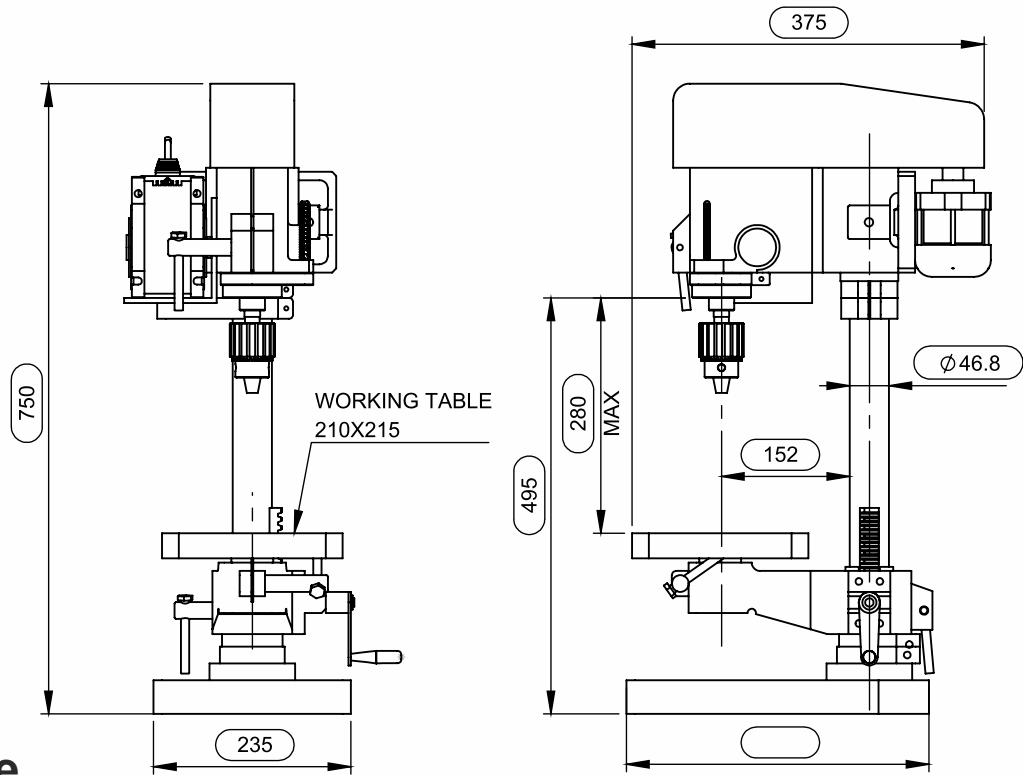

Drill machine

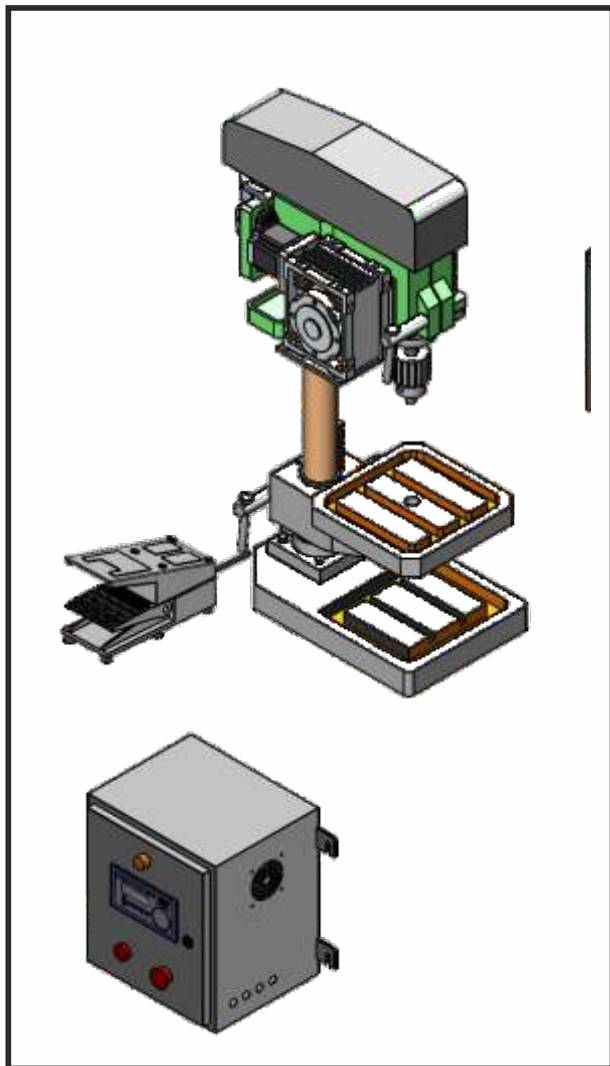

Technical Data

SR NO.	DESCRIPTION	CAPACITY & SIZE
1	DRILLING CAPACITY IN STEEL	13
2	SPINDLE TRAVEL MAXIMUM	80
3	SPINDLE TAPER	SOLID
4	NO OF SPINDLE SPEED	04
5	COLUMN DIAMETER	46.8
6	MAX DISTANCE BETWEEN SPINDLE CENTRE TO COLUME FACE	152
7	MAX DISTANCE BETWEEN SPINDLE NOSE TO WORKING TABLE	280
8	MAX DISTANCE BETWEEN SPINDLE NOSE TO BASE PATE	495
9	WORKING TABLE SIZE	210X215
10	ELECTRIC MOTOR	3 PHASE ,0.5 HP, 1440 RPM
11	ELECTRIC MOTOR (OPTIONAL)	SINGLE PHASE (0.5HP,1440RPM)
12	V-BELT SIZE	M-2360
13	SIZE OF BASE PLATE	235X360
14	OVERALL DIMENSION OF MACHINE	750H X335W X375L
15	WEIGHT OF MACHINE	55Kg
16	Feed rate of Z Axis (Rapid)	40 mm/sec
17	Drilling feed rate	3mm/sec
18	Controller Input / Output	2 Input /3 Output
19	Power consumption	950W

Mechanical Dimension for Control Panel

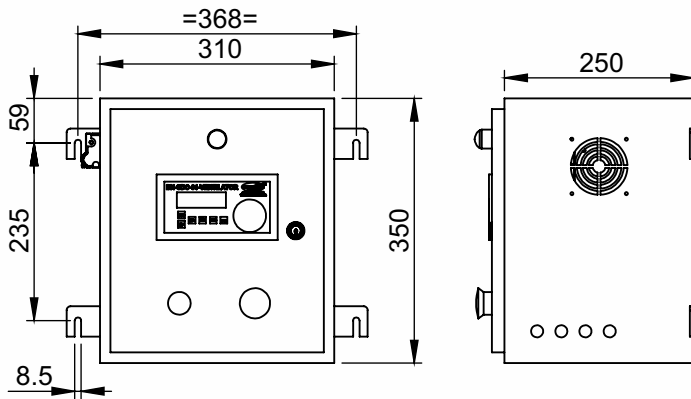

Circuit Diagram for control panel.

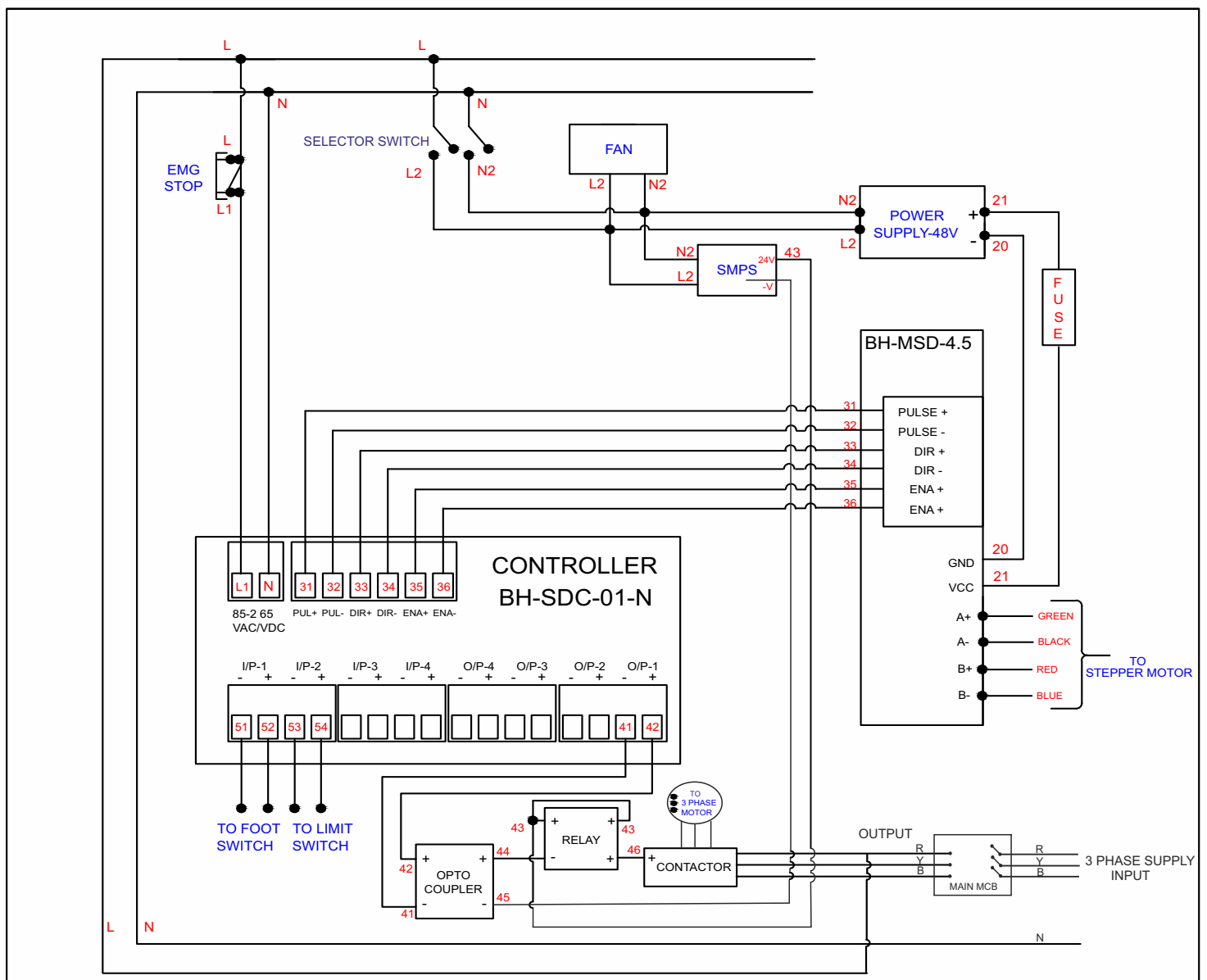

Program for Z axis Drilling Machines (Drill size 13mm & Drill Depth 10mm)

Input Configuration

Press M1 and select configuration $\xrightarrow{\text{Enter}}$ Select input $\xrightarrow{\text{Enter}}$

M1 Move:- Linear $\xrightarrow{\text{Enter}}$	M1 Time:- Second $\xrightarrow{\text{Enter}}$
M1 Micro step:- 002 $\xrightarrow{\text{Enter}}$	M1 Linear speed unit } $\xrightarrow{\text{Enter}}$
M1 Pitch:- 5mm $\xrightarrow{\text{Enter}}$ (As per Drilling Machine)	speed : mm/sec } $\xrightarrow{\text{Enter}}$
M1 Max Length:- 1000mm $\xrightarrow{\text{Enter}}$	No of Limit SW: 4 $\xrightarrow{\text{Enter}}$
M1 Speed:- RPM $\xrightarrow{\text{Enter}}$	Jog mode: No $\xrightarrow{\text{Enter}}$
M1 Step unit:- step $\xrightarrow{\text{Enter}}$	

Output Configuration

Press M1 and select configure $\xrightarrow{\text{Enter}}$ Select system $\xrightarrow{\text{Enter}}$

Set parameter } $\xrightarrow{\text{Enter}}$
 Mode :- Auto

Program:- New $\xrightarrow{\text{Enter}}$

Select Program no :- 1 $\xrightarrow{\text{Enter}}$

C001 M1 ON $\xrightarrow{\text{Enter}}$

M Dir :- CCW $\xrightarrow{\text{Enter}}$

M1 Distance:- 500mm $\xrightarrow{\text{Enter}}$

M1 Speed:- 10mm/sec $\xrightarrow{\text{Enter}}$

M1 Acc:- 0.2sec $\xrightarrow{\text{Enter}}$

M1 Dec:- 0.2sec $\xrightarrow{\text{Enter}}$

M1 Start at :- SW $\xrightarrow{\text{Enter}}$

M1 Start at SW :- S1 $\xrightarrow{\text{Enter}}$

M1 Start at SW :- S1H $\xrightarrow{\text{Enter}}$

M1 Stop at SW $\xrightarrow{\text{Enter}}$

M1 Stop at SW:- S2 $\xrightarrow{\text{Enter}}$

M1 Stop at SW:- S2 H $\xrightarrow{\text{Enter}}$

C001 at start : OP1 $\xrightarrow{\text{Enter}}$ OP2 $\xrightarrow{\text{Enter}}$ OP3 $\xrightarrow{\text{Enter}}$ OP4 $\xrightarrow{\text{Enter}}$

C001 at End : OP1 $\xrightarrow{\text{Enter}}$ OP2 $\xrightarrow{\text{Enter}}$ OP3 $\xrightarrow{\text{Enter}}$ OP4 $\xrightarrow{\text{Enter}}$

Present cycle : 001 } $\xrightarrow{\text{Enter}}$
 Next cycle : C002

C002 type: Run $\xrightarrow{\text{Enter}}$

C002 M1: ON $\xrightarrow{\text{Enter}}$

M1 Dir: CW $\xrightarrow{\text{Enter}}$

M1 Distance: 20mm $\xrightarrow{\text{Enter}}$ (For Rapid)

M1 speed : 40mm/sec $\xrightarrow{\text{Enter}}$

M1 Acc : 0.1sec $\xrightarrow{\text{Enter}}$

M1 Dec : 0.1sec $\xrightarrow{\text{Enter}}$

M1 start at :- SW $\xrightarrow{\text{Enter}}$

M1 start at SW:- S1 $\xrightarrow{\text{Enter}}$

M1 start at SW:- S1H $\xrightarrow{\text{Enter}}$

M1 stop at :- Direct $\xrightarrow{\text{Enter}}$

C002 at start : OP1 $\xrightarrow{\text{Enter}}$ OP2 $\xrightarrow{\text{Enter}}$ OP3 $\xrightarrow{\text{Enter}}$ OP4 $\xrightarrow{\text{Enter}}$

C002 at End : OP1 $\xrightarrow{\text{Enter}}$ OP2 $\xrightarrow{\text{Enter}}$ OP3 $\xrightarrow{\text{Enter}}$ OP4 $\xrightarrow{\text{Enter}}$

Present cycle : 002 } $\xrightarrow{\text{Enter}}$
 Next cycle : C003

C003 type: Run $\xrightarrow{\text{Enter}}$

C003 M1: ON $\xrightarrow{\text{Enter}}$

M1 Dir: CW $\xrightarrow{\text{Enter}}$

M1 Distance: 10mm $\xrightarrow{\text{Enter}}$ (For Drill Depth)

M1 speed : 3mm/sec $\xrightarrow{\text{Enter}}$

M1 Acc : 0.2sec $\xrightarrow{\text{Enter}}$

M1 Dec : 0.1sec $\xrightarrow{\text{Enter}}$

M1 start at :- Direct $\xrightarrow{\text{Enter}}$

M1 stop at :- Direct $\xrightarrow{\text{Enter}}$

C003 at start : OP1 $\xrightarrow{\text{Enter}}$ OP2 $\xrightarrow{\text{Enter}}$ OP3 $\xrightarrow{\text{Enter}}$ OP4 $\xrightarrow{\text{Enter}}$

C003 at End : OP1 $\xrightarrow{\text{Enter}}$ OP2 $\xrightarrow{\text{Enter}}$ OP3 $\xrightarrow{\text{Enter}}$ OP4 $\xrightarrow{\text{Enter}}$

Present cycle : 003 } $\xrightarrow{\text{Enter}}$
 Next cycle : C004

C004 type: Run $\xrightarrow{\text{Enter}}$

C004 M1: ON $\xrightarrow{\text{Enter}}$

M1 Dir: CCW $\xrightarrow{\text{Enter}}$

M1 Distance: 20mm $\xrightarrow{\text{Enter}}$ (For Drill Depth)

M1 speed : 60mm/sec $\xrightarrow{\text{Enter}}$

M1 Acc : 0.2sec $\xrightarrow{\text{Enter}}$

M1 Dec : 0.2sec $\xrightarrow{\text{Enter}}$

M1 start at :- Direct $\xrightarrow{\text{Enter}}$

M1 stop at :- Direct $\xrightarrow{\text{Enter}}$

C004 at start : OP1 $\xrightarrow{\text{Enter}}$ OP2 $\xrightarrow{\text{Enter}}$ OP3 $\xrightarrow{\text{Enter}}$ OP4 $\xrightarrow{\text{Enter}}$

C004 at End : OP1 $\xrightarrow{\text{Enter}}$ OP2 $\xrightarrow{\text{Enter}}$ OP3 $\xrightarrow{\text{Enter}}$ OP4 $\xrightarrow{\text{Enter}}$

Present cycle : 004 } $\xrightarrow{\text{Enter}}$
 Next cycle : C002

Auto Program No 1 (Completed)